



Kenya Power

**TENDER NO : KP3/9A/OT/03/17-18
FOR SUPPLY OF MOTOR VEHICLES, MOTOR CYCLES & PLANT**

AUGUST 2017

**ALL TENDERERS ARE ADVISED TO READ CAREFULLY THIS TENDER
DOCUMENT IN ITS ENTIRETY BEFORE MAKING ANY BID**

**TENDER DOCUMENT FOR SUPPLY OF GOODS
(E-PROCUREMENT SYSTEM)**

THE KENYA POWER & LIGHTING COMPANY LIMITED
CENTRAL OFFICE, STIMA PLAZA,
KOLOBOT ROAD, PARKLANDS,
P.O. BOX 30099-00100,
NAIROBI,
KENYA.

Telephones: +254-020-3201000; 3644000 Pilot Lines
Telephones: +254 -720-600070/1-5/; -733-755001/2-3 Cellular
Website: www.kplc.co.ke
Email 1: JOchieng@kplc.co.ke
2: PKatoni@kplc.co.ke
3: Lmitine@kplc.co.ke

TABLE OF CONTENTS

SECTION I - INVITATION TO TENDER.....	3
SECTION II - TENDER SUBMISSION CHECKLIST.....	4
SECTION III - INSTRUCTIONS TO TENDERERS	8
SECTION IV – SCHEDULE OF REQUIREMENTS	27
SECTION V – PRICE SCHEDULE OF OF GOODS	28
SECTION VI - EVALUATION CRITERIA.....	31
SECTION VII – GENERAL CONDITIONS OF CONTRACT	36
SECTION VIII – SPECIAL CONDITIONS OF CONTRACT	47
SECTION IX - TENDER FORM.....	48
SECTION X – CONFIDENTIAL BUSINESS QUESTIONNAIRE FORM.....	50
SECTION XI A - TENDER SECURITY FORM – (BANK GUARANTEE).....	53
SECTION XI B - TENDER SECURITY FORM (SACCO SOCIETY, DEPOSIT TAKING MICRO FINANCE INSTITUTIONS, WOMEN ENTERPRISE FUND & YOUTH ENTERPRISE FUND)	56
SECTION XI C - TENDER SECURITY – (LETTERS OF CREDIT).....	59
SECTION XII A - MANUFACTURER’S AUTHORIZATION FORM.....	61
SECTION XIIB - MANUFACTURER’S WARRANTY FORM.....	62
SECTION XIII - DECLARATION FORM.....	63
SECTION XIV – DRAFT LETTER OF NOTIFICATION OF AWARD	64
SECTION XV – DRAFT LETTER OF NOTIFICATION OF REGRET	65
SECTION XVI - CONTRACT AGREEMENT FORM.....	66
SECTION XVII A - PERFORMANCE SECURITY FORM (BANK GUARANTEE) ..	71
SECTION XVII B - PERFORMANCE SECURITY (LC)	73
SECTION XVIII – SUBCONTRACTORS.....	75
SECTION XIX - PREVIOUS EXPERIENCE WITH SIMILAR WORK	76
SECTION XX - SUPPLIER EVALUATION FORM.....	77
SECTION XXI - THE TECHNICAL SPECIFICATIONS	79

SECTION I - INVITATION TO TENDER

DATE: AUGUST, 2017

TENDER REFERENCE NUMBER: KP3/9A/OT/03/17-18 FOR SUPPLY OF MOTOR VEHICLES, MOTOR CYCLES & PLANT.

1.1 **Introduction.**

The Kenya Power & Lighting Company Ltd (KPLC) invites bids from eligible Tenderers for **Supply of Motor Vehicles, Motor Cycles, & Plant.**

Interested eligible Tenderers may obtain further information from the General Manager-Supply Chain, The Kenya Power & Lighting Company Ltd at Stima Plaza, 3rd Floor, Kolobot Road, P.O. Box 30099 – 00100 Nairobi, Kenya.

1.2 **Obtaining tender documents.**

1.2.1 Tender documents detailing the requirements may be obtained from the KPLC E-Procurement Portal as from **29th August, 2017**

1.2.2 Prospective bidders may also download the tender document from KPLC's website (www.kplc.co.ke) free of charge.

1.3 **Submission of Tender documents**

Completed Tenders are to be submitted in electronic format on the KPLC's E-procurement portal on the due date and time published on the portal. Tenderers are required to visit the portal from time to time for revised closing dates and addendums. The Tender is to be submitted **ONLINE** on or before **13th September, 2017 at 10.30 a.m.**

1.4 **Prices**

Offered Price should be inclusive of all taxes, duties, levies and delivery costs to the premises (where applicable) of KPLC or other specified site must be in Kenya Shillings or a freely convertible currency in Kenya and shall remain valid for one hundred and twenty (120) days from the closing date of the tender..

1.5 **Opening of submitted Tenders**

Tenders will be opened promptly thereafter (**13th September 2017 at 10.30 a.m.**) in the presence of the Tenderer's or their representatives who choose to attend in KPLC Auditorium at Stima Plaza, Kolobot Road, Parklands, Nairobi

SECTION II - TENDER SUBMISSION CHECKLIST

Bidders are advised to clearly label their documents while uploading on the portal.

No.	Item	Tick Where Provided
1	Tender Security – Bank Guarantee or Letters of Credit (issued by Banks Licensed by the Central Bank of Kenya), Guarantee by a deposit taking Microfinance Institution, Sacco Society, the Youth Enterprise Development Fund or the Women Enterprise Fund.	
2	Declaration Form	
3	Duly completed Tender Form	
4	Copy of Company or Firm’s Registration Certificate	
5*	Copy of PIN Certificate	
6*	Copy of Valid Tax Compliance Certificate	
7	Confidential Business Questionnaire (CBQ)	
8	Type Test Certificates and their Reports and or Test Certificates and their Reports	
9	Copy of accreditation certificate for the testing laboratory as per ISO/ IEC 17025,	
10	Valid and current ISO 9001 Certificates or for locally manufactured or produced goods, valid Mark of Quality Certificate or Standardization Mark Certificates from the Kenya Bureau of Standards (KEBS).	
11	Catalogues and or Brochures and or Manufacturers drawings	
12	Duly completed Schedule of Guaranteed Technical Particulars	
13	Manufacturer’s Authorisation and warranty	
14	Names with full contact as well as physical addresses of previous customers of similar goods and reference letters from at least four (4) previous customers	
15	Statement on Deviations	
16	Price Schedule(s)	
17	Schedule of requirements duly filled indicating items offered	
18	<p>Financial Statements. The audited financial statements required must be those that are reported within eighteen (18) calendar months of the date of the tender document.</p> <p><i>(For companies or firms that are registered or incorporated within the last one calendar year of the Date of the Tender Document, they should submit certified copies of bank statements covering a period of at least six months prior to the date of the tender document. The copies should be certified by the Bank issuing the statements. The certification should be original).</i></p>	
20	Any other document or item required by the Tender Document. (The Tenderer shall specify such other documents or items it has submitted)	
21	Samples if required	

***NOTES TO TENDERERS**

1. Valid Tax Compliance Certificate shall be one issued by the relevant tax authorities and valid for at least up to the tender closing date. All Kenyan registered Tenderers must provide a valid Tax Compliance Certificate.
2. All Kenyan registered Tenderers must provide the Personal Identification Number Certificate (PIN Certificate).
3. Foreign Tenderers must provide equivalent documents to Tax Compliance and PIN certificates from their country of origin OR statements certifying that the equivalent documentation is not issued in the Tenderer's country of origin. Such Statement(s) shall be original and issued by the Tax authorities in the Tenderer's country of origin.

TABLE OF PARAGRAPHS ON INSTRUCTIONS TO TENDERERS

Paragraph No.	Headings	Page No.
3.1	Definitions	8
3.2	Eligible Tenderers	9
3.3	Eligible Goods	10
3.4	Cost of Tendering	10
3.5	Contents of The Tender Document	10
3.6	Clarification of Documents	11
3.7	Amendment of Documents	11
3.8	Language of Tender	12
3.9	Documents Comprising the Tender	12
3.1	Tender Form	12
3.11	Tender Prices	12
3.12	Tender Currencies	13
3.13	Tenderer's Eligibility and Qualifications	13
3.14	Unsatisfactory or default in performance	14
3.15	Goods' Eligibility and Conformity to Tender Documents	14
3.16	Sample(s)	15
3.17	Warranty	15
3.18	Tender Security	15
3.19	Validity of Tenders	17
3.2	Alternative Offers	17
3.21	Deadline for Submission of Tender	17
3.22	Modification and Withdrawal of Tenders	17
3.23	Opening of Tenders	18
3.24	Process To Be Confidential	18
3.25	Clarification of Tenders	18
3.26	Preliminary Tender Evaluation	19
3.27	Minor Deviations, Errors or Oversights	19
3.28	Technical Evaluation of Tenders	19
3.29	Financial Evaluation of Tenders	19
3.3	Preferences of a Tenderer	20
3.31	Debarment of a Tenderer	20
3.32	Confirmation of Qualification for Award	20
3.33	Award of Contract	21
3.34	Termination of Procurement Proceedings	21
3.35	Notification of Award	21
3.36	Signing of Contract	21
3.37	Performance Security	22

SECTION III - INSTRUCTIONS TO TENDERERS

3.1 Definitions

In this tender, unless the context or express provision otherwise requires: -

- a) *Any reference to any Act shall include any statutory extension, amendment, modification, re-amendment or replacement of such Act and any rule, regulation or order made there-under.*
- b) *“Date of Tender Document” shall be the **start date** specified on the KPLC tendering portal.*
- c) *“Day” means calendar day and “month” means calendar month.*
- d) *“KEBS” wherever appearing means the Kenya Bureau of Standards or its successor(s) and assign(s) where the context so admits.*
- e) *“KENAS” wherever appearing means the Kenya National Accreditation Service or its successor(s) and assign(s) where the context so admits*
- f) *“PPRA” wherever appearing means The Public Procurement Regulatory Authority or its successor(s) and assign(s) where the context so admits.*
- g) *Reference to “the tender” or the “Tender Document” includes its appendices and documents mentioned hereunder and any reference to this tender or to any other document includes a reference to the other document as varied supplemented and/or replaced in any manner from time to time.*
- h) *“The Procuring Entity” means The Kenya Power and Lighting Company Limited or its successor(s) and assign(s) where the context so admits (hereinafter abbreviated as KPLC).*
- i) *“The Tenderer” means the person(s) submitting its Tender for the supply, installation and commissioning (where applicable) of the goods in response to the Invitation to Tender.*
- j) *Where there are two or more persons included in the expression the “Tenderer”, any act or default or omission by the Tenderer shall be deemed to be an act, default or omission by any one or more of such persons.*
- k) *Words importing the masculine gender only, include the feminine gender or (as the case may be) the neutral gender.*
- l) *Words importing the singular number only include the plural number and vice-versa and where there are two or more persons included in the expression the “Tenderer” the covenants, agreements and obligations expressed to be made or performed by the Tenderer shall be deemed to be made or performed by such persons jointly and severally.*
- m) *KPLC’s “authorised person” shall mean its MD & CEO who is designated by the PPAD Act 2015 to exercise such power, authority or discretion as is required under*

the tender and any contract arising therefrom, or such other KPLC staff delegated with such authority.

- n) *Citizen contractors-means a person/firm wholly owned and controlled by person(s) who are citizens of Kenya.*
- o) *Local contractors- a firm shall be qualified as a local contractor if it is registered in Kenya.*

3.2 Eligible Tenderers

3.2.1 A tenderer is eligible to bid for this contract only if the tenderer satisfies the following criteria—

- (a) the tenderer has the legal capacity to enter into a contract for procurement or asset disposal;
- (b) the tenderer is not insolvent, in receivership, bankrupt or in the process of being wound up;
- (c) the tenderer, if a member of a regulated profession, has satisfied all the professional requirements;
- (d) the tenderer and his or her sub-contractor, if any, is not debarred;
- (e) the tenderer has fulfilled tax obligations;
- (f) the tenderer has not been convicted of corrupt or fraudulent practices; and
- (g) is not guilty of any serious violation of fair employment laws and practices.

In addition, this Invitation to Tender is open to all Tenderers eligible as described in the **Appendix to Instructions to Tenderers.**

Successful Tenderers shall supply the goods in accordance with this tender and the ensuing contract.

3.2.2 In addition the tenderer shall be considered ineligible to bid, where in case of a corporation, private company, partnership or other body, the tenderer, their spouse, child or sub-contractor has substantial or controlling interest and is found to be in contravention of the provisions of section 3.2.1 above.

3.2.5 Despite the provisions of section 3.2.3 and 3.2.4, a tenderer having a substantial or controlling interest shall be eligible to bid where—

- (a) such tenderer has declared any conflict of interest; and
- (b) performance and price competition for that good, work or service is not available or can only be sourced from that tenderer.

3.2.6 For the purposes of this paragraph, any relative i.e. spouse(s) and child (ren) of any person mentioned in sub-paragraph 3.2.3 is also ineligible to participate in the tender. In addition, a Cabinet Secretary shall include the President, Deputy President or the Attorney General of GoK.

- 3.2.7 Tenderers shall provide the qualification information statement that the Tenderer (including subcontractors) is not associated, or have been associated in the past, directly or indirectly, with a firm or any of its affiliates which have been engaged by KPLC to provide consulting services for the preparation of the design, specifications, and other documents to be used for the procurement of the goods under this Invitation to Tender.
- 3.2.8 Tenderers shall not be under declarations as prescribed at Section XIII.
- 3.2.9 Tenderers who are not under these declarations shall complete the Declaration Form strictly in the form and content as prescribed at Section XIII.
- 3.2.10 Those that are under the Declaration as prescribed at Section XIII whether currently or in the past shall not complete the Form. They will submit a suitable Form giving details, the nature and present status of their circumstances.

3.3 Eligible Goods

- 3.3.1 All goods to be supplied under the contract shall have their origin in eligible source countries. These countries are as described in the Appendix to Instructions to Tenderers.
- 3.3.2 For purposes of this clause, “origin” means the place where the goods are mined, grown, or produced. Goods are produced when, through manufacturing, processing, or substantial and major assembly of components, a commercially recognized product results that is substantially different in basic characteristics or in purpose or utility from its components.
- 3.3.3 The origin of goods is distinct from the nationality of the Tenderer.

3.4 Cost of Tendering

- 3.4.1 The Tenderer shall bear all costs associated with the preparation and submission of its Tender, and KPLC will in no case be responsible or liable for those costs, regardless of the conduct or outcome of the tendering process.

3.5 Contents of the Tender Document

- 3.5.1 The Tender Document comprises the documents listed below and Addendum (where applicable) issued in accordance with paragraph 3.7 of these Instructions to Tenderers: -

- a) *Invitation to Tender*
- b) *Tender Submission Checklist*
- c) *Instructions to Tenderers*
- d) *Appendix to Instructions to Tenderers*
- e) *Schedule of Requirements*
- f) *Delivery Schedule*
- g) *Price Schedule for Goods*
- h) *Evaluation Criteria*
- i) *General Conditions of Contract*
- j) *Special Conditions of Contract*
- k) *Tender Form*
- l) *Confidential Business Questionnaire Form*

- m) *Tender Security Form*
- n) *Manufacturer's Authorization Form*
- o) *Manufacturer's Warranty*
- p) *Declaration Form*
- q) *Contract Form*
- r) *Performance Security Form*
- s) *Technical Specifications*
 - (i) *General Requirements*
 - (ii.) *Detailed Technical Specifications*

3.5.2 The Tenderer is expected to examine all instructions, forms, provisions, terms and specifications in the Tender Document. Failure to furnish all information required by the Tender Document or to submit a tender not substantially responsive to the Tender Document in every respect will be at the Tenderer's risk and may result in the rejection of its Tender.

3.5.3 All recipients of the documents for the proposed Contract for the purpose of submitting a tender (*whether they submit a tender or not*) shall treat the details of the documents as "Private and Confidential".

3.6 Clarification of Documents

A prospective Tenderer requiring any clarification of the Tender Document may notify the General Manager Supply Chain in writing and ensure receipt is acknowledged at KPLC's Physical address indicated on the Tender Document. KPLC will respond in writing to any request for clarification of the Tender documents, which it receives not later than seven (7) days prior to the deadline for the submission of Tenders, prescribed by KPLC. Written copies of KPLC's response (*including an explanation of the query but without identifying the source of inquiry*) will be published and accessible to all prospective Tenderers on the KPLC's tendering portal.

3.7 Amendment of Documents

3.7.1 At any time prior to the deadline for submission of Tenders, KPLC, for any reason, whether at its own initiative or in response to a clarification requested by a prospective Tenderer, may modify the tender documents by amendment.

3.7.2 All prospective Tenderers that have registered in the portal for the Tender will be notified of the amendment(s) (*hereinafter referred to or otherwise known as addendum*) in writing and will be binding on them.

3.7.3 In order to allow prospective Tenderers reasonable time in which to take the amendment into account in preparing their Tenders, KPLC, at its discretion, may extend the deadline for the submission of Tenders.

3.8 Language of Tender

The Tender prepared by the Tenderer, as well as all correspondence and documents relating to the tender, exchanged between the Tenderer and KPLC, shall be written in English language. Any printed literature furnished by the Tenderer written in any other language shall be accompanied by an accurate English translation of the relevant passages, in which case, for purposes of interpretation of the Tender, the English translation shall govern. The English translation shall be on the Tenderer's letterhead and shall be signed by the duly authorized signatory signing the Tender and stamped with the Tenderer's stamp.

3.9 Documents Comprising the Tender

The Tender prepared and submitted by the Tenderer shall include but not be limited to all the following components: -

- a) *Declaration Form, Tender Form and a Price Schedule completed in compliance with paragraphs 3.2, 3.10, 3.11 and 3.12.*
- b) *Documentary evidence established in accordance with paragraph 3.13 that the Tenderer is eligible to tender and is qualified to perform the contract if its tender is accepted.*
- c) *Documentary evidence established in accordance with paragraph 3.14 that the goods and ancillary services to be supplied by the Tenderer are eligible goods and services and conform to the tender documents, and,*
- d) *Tender Security furnished in accordance with paragraph 3.18*
- e) *A detailed list of previous customers as prescribed for similar items on tender and their contact addresses shall be submitted with the Tender for the purpose of reference,*
- f) *And all other documents indicated in Section II (Tender Submission Checklist)*

3.10 Tender Form

- 3.10.1 The Tenderer shall complete and sign the Tender Form and all other documents furnished in the Tender Document, indicating the goods to be supplied, a brief description of the goods, their country of origin, quantity, and prices amongst other information required.
- 3.10.2 If the Form is found to have insufficient space to fit all of the Tenderer's information, data, etc., the Tenderer shall attach a sheet or sheets immediately after such page clearly labeling at the top of each page of such attachment with the title of that Form and numbering accordingly.

3.11 Tender Prices

- 3.11.1 The Tenderer shall indicate on the appropriate Price Schedule, the unit prices and total tender price of the goods it proposes to supply under the contract.
- 3.11.2 Prices indicated on the Price Schedule shall include all costs including taxes, insurances and delivery to the premises (where applicable) of KPLC or other specified site.
- 3.11.3. For the avoidance of doubt, Tenderers shall quote on Delivered Duty Paid (DDP) basis. No other basis shall be accepted for evaluation, award or otherwise.

3.11.4 Tender prices to be submitted (quoted) by the Tenderer shall remain fixed for the contract duration.

3.12 Tender Currencies

3.12.1 For goods that the Tenderer will supply from within or outside Kenya, the prices shall be quoted in Kenya Shillings, or in another freely convertible currency in Kenya. The currency quoted must be indicated clearly on the Price Schedule of Goods.

3.12.2 The exchange rate to be used for currency conversion for evaluation purposes shall be the Central Bank of Kenya selling rate prevailing on the Tender closing date. (Please visit the Central Bank of Kenya website).

3.13 Tenderer's Eligibility and Qualifications

3.13.1 Pursuant to paragraph 3.2, the Tenderer shall furnish, as part of its Tender, documents establishing the Tenderer's eligibility to tender and its qualifications to perform the contract if its Tender is accepted.

3.13.2 The documentary evidence of the Tenderer's eligibility to tender shall establish to KPLC's satisfaction that the Tenderer, at the time of submission of its Tender, is from an eligible source country as defined under paragraph 3.2

3.13.3 The documentary evidence of the Tenderer's qualifications to perform the contract if its Tender is accepted shall be established to KPLC's satisfaction –

- a) *that, in the case of a Tenderer offering to supply goods under the contract which the Tenderer did not manufacture or otherwise produce, the Tenderer has been duly authorized by the goods' manufacturer or producer to supply the goods. The authorization shall strictly be in the form and content as prescribed in the Manufacturer's Authorization Form in the Tender Document.*
- b) *that the Tenderer has the financial capability necessary to perform the contract. The Tenderer shall be required to provide the documents as specified in the Appendix to Instructions to Tenderers including a current Tax Compliance Certificate issued by the relevant tax authorities.*
- c) *that the Tenderer has the technical and production capability necessary to perform the contract.*
- d) *that, in the case of a Tenderer not doing business within Kenya, the Tenderer is or will be (if awarded the contract) represented by an agent in Kenya equipped and able to carry out the Tenderer's maintenance, repair, spare parts and stocking obligations prescribed in the Conditions of Contract and or in the Technical Specifications.*

3.14 Unsatisfactory or default in performance

Tenderers with any record of unsatisfactory or default in performance obligations in any contract shall not be considered for evaluation, award or otherwise. For the avoidance of

doubt, this shall include any Tenderer with unresolved case(s) in its performance obligations for more than two (2) months in any contract.

3.15 Goods Eligibility and Conformity to Tender Documents

- 3.15.1 Pursuant to paragraph 3.3 of this Section, the Tenderer shall furnish, as part of its Tender, documents establishing the eligibility and conformity to the Tender Document of all goods that the Tenderer proposes to supply under the contract.
- 3.15.2 The documentary evidence of the eligibility of the goods shall consist of a statement in the Price Schedule of the country of origin of the goods and services offered which shall be confirmed by a certificate of origin issued at the time of shipment.
- 3.15.3 The documentary evidence of conformity of the goods to the Tender Document may be in the form of literature, drawings and data, and shall consist of: -
- a) *a detailed description of the essential technical and performance characteristics of the goods whether in brochures, catalogues, drawings or otherwise,*
 - b) *a list giving full particulars, including available source and current prices of spare parts, special tools and other incidental apparatus necessary for the proper and continuing functioning of the goods for a minimum period of three (3) years, following commencement of the use of the goods by KPLC, and,*
 - c) *Duly completed Schedule of Guaranteed Technical Particulars (GTP) as per Tender Specifications demonstrating substantial responsiveness of the goods and service to those specifications and, if any, a statement of deviations and exceptions to the provisions of the Technical Specifications.*
- 3.15.4 For all goods offered, the Tenderer shall be required to demonstrate that the goods or products conform to required standards by evidence of a Type Test Certificate and its Report, or, Test Certificates and their Reports issued by a **third party testing laboratory** accredited to ISO/IEC 17025. A copy of the accreditation certificate to ISO/IEC 17025 **of the testing laboratory** shall be submitted together with the tender. KPLC reserves the right to subject the certificate(s) to authentication. **Type Test Certificates and Type Test Reports shall NOT be more than five (5) years old prior to the Date of the Tender document.**
- 3.15.5 Where the Tenderer proposes to supply locally manufactured goods, and any local (*i.e. Kenyan*) testing body lacks the necessary accreditation certificate or ability mentioned in 3.15.4 above, the certificate issued by such local testing body shall be accepted within the meaning of paragraph 3.15.4 notwithstanding the absence of the accreditation certificate(s).
- 3.15.6 Where in any case not provided for in clauses 3.15.4 and 3.15.5 above, the acceptance of goods for purposes of evaluation or otherwise shall be at the sole discretion of KPLC. However, the Tenderer shall submit satisfactory evidence prior to application of this sub-paragraph.
- 3.15.7 For purposes of the documentary and other evidence to be furnished pursuant to sub-paragraphs 3.15.3, 3.15.4, 3.15.5 and 3.15.6 above, the Tenderer shall note that standards for workmanship, material, and equipment, as well as references to brand names or catalogue numbers designated by KPLC in its Technical Specifications, are intended to be descriptive

only and not restrictive. The Tenderer may adopt higher standards, brand names, and or catalogue numbers in its Tender, provided that it demonstrates to KPLC's satisfaction that the substitutions ensure substantial equivalence to those designated in the Technical Specifications.

3.16 Sample(s)

3.16.1 Where required in the Appendix to Instruction to Tenderers, all Tenderers must also submit sample(s) in conformity with the technical specifications securely and clearly labeled with -

- a) *the Tender number and name,*
- b) *the opening date and time of the tender,*
- c) *the name or identity of the sample, and,*
- d) *the name of the Tenderer.*

3.16.2 The sample(s) shall be considered as part of the tender and must be submitted on or before the deadline for submission of Tenders and receipt acknowledged by KPLC evidenced by a stamped delivery note.

3.17 Warranty

3.17.1 Where required in the Tender, all Tenderers must also provide a Warranty that warrants that the goods to be supplied under the intended contract are new, unused, of the most recent or current specification and incorporate all recent improvements in design and materials unless provided otherwise in the Tender. The Warranty shall also warrant that the goods in the Tenderer's bid have no defect arising from manufacture, materials or workmanship or from any act or omission of the Tenderer that may develop under normal use of the goods under the conditions obtaining in Kenya.

3.17.2 The Warranty will remain valid for one (1) year after the goods, or any portion thereof as the case may be, have been delivered to the final destination indicated in the contract, or for eighteen (18) months after the date of shipment from the port of loading in the source country, whichever period concludes earlier.

3.18 Tender Security

3.18.1 The Tenderer shall furnish, as part of its Tender, a tender security for the amount specified in the Appendix to Instructions to Tenderers. The Original Tender Security, in a clearly labeled envelop, shall be deposited in the **Tender Security Box at Stima Plaza 3rd Floor** on or before the opening date and time and receipt acknowledged by KPLC evidenced by a stamped copy.

3.18.2 The tender security shall be either one or a combination of the following:-

- a) an original Bank Guarantee that is strictly in the form and content as prescribed in the Tender Security Form (Bank Guarantee) in the Tender Document.
- b) For Local bidders, Standby Letters of Credit (LC). All costs, expenses and charges levied by all banks party to the LC shall be prepaid/borne by the Tenderer. The LC

must contain all the mandatory conditions of payment to KPLC as prescribed in the Tender Security (Letters of Credit) provided in the Tender Document.

- c) For Foreign bidders, Standby Letters of Credit (LC) confirmed by a bank in Kenya. All costs, expenses and charges levied by all banks party to the LC including confirmation charges shall be prepaid/borne by the Tenderer. The LC must contain all the mandatory conditions of payment to KPLC as prescribed in the Tender Security (Letters of Credit) provided in the Tender Document.
 - d) An original Guarantee by a deposit taking Microfinance Institution, Sacco Society, Youth Enterprise Development Fund or the Women Enterprise Fund, that is strictly in the form and content as prescribed in the Tender Security Form
- 3.18.3 The tender security is required to protect KPLC against the risk of the Tenderer's conduct which would warrant the security's forfeiture pursuant to paragraph 3.18.10.
- 3.18.4 The Tender Security shall be denominated in Kenya Shillings or in another freely convertible currency in Kenya.
- 3.18.5 The Tender Security shall be valid for thirty (30) days beyond the validity of the tender.
- 3.18.6 KPLC shall seek authentication of the Tender Security from the issuing or confirming bank. It is the responsibility of the Tenderer to sensitize its issuing or confirming bank on the need to respond directly and expeditiously to queries from KPLC. The period for response shall not exceed three (3) days from the date of KPLC's query. Should there be no conclusive response by the bank within this period, such Tenderer's Tender Security may be deemed as invalid and the bid rejected.
- 3.18.7 Any Tender not secured in accordance with this paragraph will be rejected by KPLC as non-responsive, pursuant to paragraph 3.29.
- 3.18.8 The unsuccessful Tenderer's Tender Security will be released as promptly as possible, in any of the following circumstances: -
- a) *the procurement proceedings are terminated*
 - b) *KPLC determines that none of the submitted Tenders is responsive*
 - c) *a contract for the procurement is entered into*
- 3.18.9 The successful Tenderer's Tender Security will be released upon the successful Tenderer's signing the Framework contract, pursuant to paragraph 3.38 and furnishing an authentic Performance Security, pursuant to paragraph 3.37.
- 3.18.10 The Tender Security shall be forfeited –
- a) *if the Tenderer withdraws its Tender after the deadline for submitting Tenders but before the expiry of the period during which the Tenders must remain valid*
 - b) *if the Tenderer fails to enter into a written contract in accordance with paragraph 3.36*
 - c) *if the successful Tenderer fails to furnish the performance security in accordance with paragraph 3.39*
 - d) *if the Tenderer fails to extend the validity of the tender security where KPLC has extended the tender validity period in accordance with paragraph 3.19.*

3.18.11 Where KPLC has extended the tender validity period in accordance with paragraph 3.18, any Tenderer who opts not to extend its tender validity shall have its Tender Security promptly returned.

3.19 Validity of Tenders

- 3.19.1 Tenders shall remain valid for ninety (90) days after the date of tender opening as specified in the Invitation to Tender or as otherwise may be prescribed by KPLC, pursuant to paragraph 3.23. A Tender that is valid for a shorter period shall be rejected by KPLC as non-responsive.
- 3.19.2 In exceptional circumstances, KPLC may extend the Tender validity period. The extension shall be made in writing. The tender security provided under paragraph 3.18 may also be extended. A Tenderer shall not be required nor permitted to

3.20 Alternative Offers

Only main offers shall be considered, as alternative offers are not acceptable

3.21 Deadline for Submission of Tenders

- 3.21.1 Tenders must be received by KPLC by the date and time specified in KPLC's tendering portal in PDF form.
- 3.21.2 KPLC may, at its discretion, extend this deadline for submission of Tenders by amending the tender documents in accordance with paragraph 3.7, in which case all rights and obligations of KPLC and the Tenderer previously subject to the initial deadline, will therefore be subject to the deadline as extended.

3.22 Modification and Withdrawal of Tenders

- 3.22.1 The Tenderer may modify or withdraw its Tender after it has submitted, provided that the modification, including substitution or withdrawal of the Tender is received by KPLC prior to the deadline prescribed for submission of tenders.
- 3.22.2 No Tender may be modified after the deadline for submission of Tenders.
- 3.22.3 No Tender may be withdrawn in the interval between the deadline for submission of tenders and the expiration of the period during which the Tender must remain valid except where KPLC extends the initial validity period. Any withdrawal of a Tender during this interval shall result in forfeiture of the Tenderer's Tender Security except where KPLC extends the initial validity period.

3.23 Opening of Tenders

- 3.23.1 KPLC shall open all Tenders promptly at the date and time specified in the KPLC tendering portal and at the location specified in the Invitation to Tender or as may otherwise be indicated.
- 3.23.2 The Tenderer's names, tender modifications or withdrawals, the presence or absence of requisite Tender Security and such other details as KPLC, at its discretion, may consider appropriate, will be announced at the opening.

- 3.23.3 At the Tender opening, tender prices, discounts, and such other details as KPLC, at its discretion, may consider appropriate will be read out.
- 3.23.4 The Tenderers or their representatives may attend the opening and those present shall sign a register evidencing their attendance.

3.24 Process to be Confidential

- 3.24.1 After the opening of tenders, information relating to the examination, clarification, evaluation and comparisons of tenders and recommendations arising there-from shall not be disclosed to a Tenderer or other person(s) not officially concerned with such process until conclusion of that process.
- 3.24.2 Conclusion of that process shall be deemed to have occurred, at the latest, by the date and time KPLC notifies the successful bidder(s). In any event, official disclosure by KPLC of any information upon conclusion of that process may only be to the unsuccessful bidders and may contain only the information permissible by law in summary form.
- 3.24.3 Any effort by a Tenderer to influence KPLC or any of its staff members in the process of examination, evaluation and comparison of tenders and information or decisions concerning the Tender may result in the disqualification of the Tenderer.

3.25 Clarification of Tenders and Contacting KPLC

- 3.25.1 To assist in the examination, evaluation and comparison of Tenders KPLC may, at its discretion, ask the Tenderer for a clarification of its Tender. The request for clarification and the response shall be in writing, and no change in the prices or substance of the Tender shall be sought, offered, or permitted.
- 3.25.2 The Tenderer is required to provide timely clarification or substantiation of the information that is essential for effective evaluation of its qualifications. It is the responsibility of the Tenderer to provide in writing the clarification or substantiation which should reach KPLC within five (5) days from the date of KPLC's query. Such writing may include by electronic mail, facsimile or postal mail. Should there be no conclusive response within this period, it shall result in the Tenderer's disqualification.
- 3.25.3 Save as is provided in this paragraph and paragraph 3.26 above, no Tenderer shall contact KPLC on any matter related to its Tender, from the time of the tender opening to the time the successful Tenderer is announced..
- 3.25.4 Any effort by a Tenderer to influence KPLC in its decisions on tender evaluation, tender comparison, tender recommendation(s) or signing of Agreement may result in the disqualification of the Tenderer.

3.26 Preliminary Tender Evaluation

- 3.26.1 Prior to the detailed Technical and Financial evaluation, KPLC will determine the substantial responsiveness of each Tender. For purposes of this tender, a substantially responsive Tender is one that conforms to the requirements of Preliminary Evaluation. KPLC's determination of

a Tender's responsiveness is to be based on the contents of the Tender itself without recourse to extrinsic evidence.

- 3.26.2 KPLC will examine the Tenders to determine whether they conform to the Preliminary Evaluation Criteria set out in the Section VI Evaluation Criteria.
- 3.26.3 Notwithstanding the contents of the foregoing sub-paragraphs, if a Tender is not substantially responsive, it will be rejected at the earliest stage of evaluation by KPLC and cannot subsequently be made responsive by the Tenderer by correction of any non-conformity.

3.27 Minor Deviations, Errors or Oversights

- 3.27.1 KPLC may waive any minor deviation in a Tender that does not materially depart from the requirements of the goods and or services set out in the Tender Document.
- 3.27.2 Such minor deviation -
 - 3.27.2.1 shall be quantified to the extent possible,*
 - 3.27.2.2 shall be taken into account in the evaluation process, and,*
 - 3.27.2.3 shall be applied uniformly and consistently to all qualified Tenders duly received by KPLC.*
- 3.27.3 KPLC may waive errors and oversights that can be corrected without affecting the substance of the Tender.

3.28 Technical Evaluation of Tenders

KPLC will evaluate and compare the Tenders that have been determined to be substantially responsive in compliance to the Technical requirements set out in the Tender Document.

3.29 Financial Evaluation of Tenders

- 3.29.1 Upon completion of the preliminary and technical evaluation, KPLC shall conduct a Financial Evaluation and comparison as set out in Section VI Evaluation Criteria.
- 3.29.2 Where other currencies are used, KPLC will convert those currencies to the same currency using the selling exchange rate prevailing on the date of tender closing provided by the Central Bank of Kenya.
- 3.29.3 Arithmetical errors shall not be corrected. The tender sum as submitted and read out during the tender opening shall be absolute and final and shall not be the subject of correction, adjustment or amendment in any way by any person or entity.

3.30 Preferences

- 3.30.1 Subject to availability and realisation of the applicable international or local standards, only such manufactured articles, materials or supplies wholly mined and produced in Kenya shall be subject to preferential procurement.
- 3.30.2 Despite the above provisions, preference shall be given to —
 - (a) manufactured articles, materials and supplies partially mined or produced in Kenya or where applicable have been assembled in Kenya; or
 - (b) firms where Kenyans are shareholders.

- 3.30.3 The threshold for the provision under 3.30.2 (b) shall be above fifty-one percent of Kenyan shareholders.
- 3.30.4 Where a person is entitled to more than one preference scheme, the scheme with the highest advantage to the person shall be applied.
- 3.30.5 In the evaluation of tenders, exclusive preference shall firstly be given to citizen contractors where the amount of the tender as evaluated is below Ksh. 500 Million in respect of works, goods and services.
- 3.30.6 For purposes of this paragraph the Tenderer shall submit with its Tender, a valid copy of certificate of Confirmation of Directorships and Shareholding issued **and signed** by either the Registrar of Companies or Registrar of Business Names. This certificate must not be more than three (3) months old from the Date of the Tender Document. Kenya Power reserves the right to subject the certificate to authentication.

3.31 Debarment of a Tenderer

A Tenderer who gives false information in the Tender about its qualification or who refuses to enter into a contract after notification of contract award shall be considered for debarment from participating in future public procurement.

3.32 Confirmation of Qualification for Award

- 3.32.1 KPLC may confirm to its satisfaction whether the Tenderer that is selected as having submitted the lowest evaluated responsive tender is qualified to perform the contract satisfactorily.
- 3.32.2 The confirmation will take into account the Tenderer's financial, technical, and production capabilities. It will be based upon an examination of the documentary evidence of the Tenderer's qualifications submitted by the Tenderer, pursuant to paragraph 3.13 as well as confirmation of such other information as KPLC deems necessary and appropriate. This may include factory and other facilities inspection and audits.
- 3.32.3 An affirmative confirmation will be a prerequisite for award of the contract to the Tenderer. A negative confirmation will result in rejection of the Tenderer's Tender, in which event KPLC will proceed to the next lowest evaluated responsive tender to make a similar confirmation of that Tenderer's capabilities to perform satisfactorily.

3.33 Award of Contract

- 3.33.1 KPLC will award the contract to the successful Tenderer whose Tender has been determined to be substantially responsive, technically compliant and has been determined to be the lowest evaluated tender, and further, where deemed necessary, that the Tenderer is confirmed to be technically and financially qualified to perform the contract satisfactorily.
- 3.33.2 Award will be done as indicated in the Appendix to Instructions to Tenderers.

3.34 Termination of Procurement Proceedings

- 3.346.1 KPLC may at any time terminate procurement proceedings before entering into a contract and shall not be liable to any person for the termination.
- 3.34.2 KPLC shall give prompt notice of the termination to the Tenderers, and, on request from any Tenderer, give its reasons for termination within fourteen (14) days of such request.

3.35 Notification of Award

- 3.35.1 Prior to the expiration of the period of tender validity, KPLC shall notify the successful Tenderer in writing that its Tender has been accepted.
- 3.35.2 The notification of award shall not constitute the formation of the contract until one is finally signed by both parties.
- 3.35.3 Simultaneously, and without prejudice to the contents of paragraph 3.35, on issuance of Notification of Award to the successful Tenderer, KPLC shall notify each unsuccessful Tenderer.
- 3.35.4 A notification of the tender outcome does not reduce the validity period for any tender security whether the Tenderer is successful or not, except where such tender security is officially released to the Bank and/or the Tenderer and such Bank discharged of all its obligations by KPLC prior to the expiry of its stated validity period.

3.36 Signing of Contract

- 3.36.1 At the same time as KPLC notifies the successful Tenderer that its Tender has been accepted, KPLC will send the Tenderer the Contract Agreement provided in the Tender Document together with any other necessary documents incorporating all agreements between the Parties.
- 3.36.2 Within fourteen (14) days of the date of notification of award, the successful Tenderer shall only sign the Contract Form and all the documents specified in that Form and return them to KPLC within that period of fourteen (14) days.
- 3.36.3 KPLC shall sign and date the Contract not earlier than fourteen (14) days from the date of notification of contract award. Further, KPLC shall not sign the contract until and unless the authentic performance security is received in accordance with paragraph 3.35.
- 3.36.4 Failure of the successful Tenderer to sign the Contract, the award shall be annulled and its tender security forfeited in which event KPLC shall notify the next lowest evaluated Tenderer that its Tender has been accepted.
- 3.36.5 Paragraph 3.36 together with the provisions of this paragraph 3.35 will apply with necessary modifications with respect to the Tenderer notified under sub-paragraph 3.35.4.

3.37 Performance Security

- 3.37.1 Within fourteen (14) days of the date of notification of award from KPLC, the successful Tenderer shall furnish KPLC with a Performance Security which shall be either one or a combination of the following:

TENDER FOR SUPPLY OF MOTOR VEHICLES, MOTOR CYCLES & PLANT- AUGUST 2017

- a) an original Bank Guarantee that is strictly in the form and content as prescribed in the Performance Security Form (Bank Guarantee) in the Tender Document.
 - b) For Local bidders, Standby Letters of Credit (LC). All costs, expenses and charges levied by all banks party to the LC shall be prepaid/borne by the Tenderer. The LC must contain all the mandatory conditions of payment to KPLC as prescribed in the Tender Security (Letters of Credit) provided in the Tender Document.
 - c) For Foreign bidders, Standby Letters of Credit (LC) confirmed by a bank in Kenya. All costs, expenses and charges levied by all banks party to the LC including confirmation charges shall be prepaid/borne by the Tenderer. The LC must contain all the mandatory conditions of payment to KPLC as prescribed in the Tender Security (Letters of Credit) provided in the Tender Document.
- 3.37.2 The Performance Security shall be denominated in Kenya Shillings or in another freely convertible currency in Kenya. A Performance Security in form of a Bank Guarantee or a Standby Letter of Credit issued on behalf of local bidders, should be from a commercial bank licensed by the Central Bank of Kenya. A Performance Security in form of a Standby Letter of Credit issued on behalf of foreign bidders by foreign banks should be confirmed by a commercial bank licensed by the Central Bank of Kenya.
- 3.37.3 The Performance Security shall be the sum of ten percent (10%) of the contract value. It shall be in the currency of the contract price.
- 3.37.4 KPLC shall seek authentication of the Performance Security from the issuing bank. It is the responsibility of the successful Tenderer to sensitize its issuing bank on the need to respond directly and expeditiously to queries from KPLC. The period for response shall not exceed three (3) days from the date of KPLC's query. Should there be no conclusive response by the Bank within this period, such successful Tenderer's Performance Security may be deemed as invalid.
- 3.37.5 Failure of the successful Tenderer to furnish an authentic Performance Security, the award shall be annulled and the Tender Security forfeited, in which event KPLC may notify the next lowest evaluated Tenderer that its Tender has been accepted.
- 3.37.6 Paragraph 3.37, 3.36 together with the provisions of this paragraph 3.39 will apply with necessary modifications, and as far as circumstances permit, with respect to the Tenderer notified under sub-paragraph 3.39.5.

3.38 Corrupt or Fraudulent Practices

- 3.38.1 KPLC requires that Tenderers observe the highest standard of ethics during the procurement process and execution of contracts. When used in the present Regulations, the following terms are defined as follows: -
- a) *“Corrupt practice” means the offering, giving, receiving or soliciting of anything of value to influence the action of public official in the procurement process or in contract execution;*
 - b) *“Fraudulent practice” means a misrepresentation of facts in order to influence a procurement process or the execution of a contract to the detriment of KPLC, and*

includes collusive practice among Tenderers (prior to or after Tender submission) designed to establish tender prices at artificial non-competitive levels and to deprive KPLC of the benefits of free and open competition.

- 3.38.2 KPLC will nullify its notification of award if it determines that the Tenderer recommended has engaged in corrupt or fraudulent practices in competing for the contract in question.
- 3.38.3 Further, a Tenderer who is found to have indulged in corrupt or fraudulent practices risks being debarred from participating in public procurement in Kenya.

APPENDIX TO INSTRUCTIONS TO TENDERERS

The following information regarding the particulars of the tender shall complement and or amend the provisions of the Instructions to Tenderers *hereinafter abbreviated as ITT*. Wherever there is a conflict between the provisions of the ITT and the Appendix, the provisions of the Appendix herein shall prevail over those of the ITT.

No.	ITT Reference Clause	Particulars of Appendix
1.	3.3.1 Eligible Tenderers	<p><i>1. For tender to be awarded in lots:</i> <i>This Invitation to Tender is open to Manufacturers or Agents/ Authorized suppliers. (Local Appointed Dealers and Agents of Motor Cycles & Plant). A manufacturer can quote directly OR authorize any number of Agents/ Authorized Suppliers to quote products from their factory.</i></p>
2.	3.3.2 Origin of Eligible goods	<p><i>All countries are eligible where otherwise stated. All tenderers shall state the origin of goods.</i></p>
3.	3.9 (e) Documents Comprising the Tender – List of Previous Customers	<p><i>The Tenderer shall submit at least four (4) names with full contact as well as physical addresses of previous customers of similar goods together with a letter from each of them confirming completion of the contracts on schedule.</i></p>
4.	3.13.3 (a) Manufacturer's Authorization	<p><i>Manufacturers Authorization on Manufacturer's Letter Head and originally signed by the manufacturer's authorized signatory.</i></p>
5.	3.13.3 (b) Documentary evidence of financial capability	<p><i>The audited financial statements required must be those that are reported within eighteen (18) calendar months of the date of the tender document. (For companies or firms that are registered or incorporated within the last one calendar year of the Date of the Tender Document, they should submit certified copies of bank statements covering a period of at least six months prior to the date of the tender document. The copies should be certified by the Bank issuing the statements. The certification should be original).</i></p>
6.	3.13.3 (c) and (d) Documents of evidence of eligibility	<p><i>i.) That the Tenderer has the technical and production capability necessary to perform the contract. ii.) That, in case of a Tenderer is or will be (if awarded the contract) represented by an agent in Kenya equipped and</i></p>

		<i>able to carry out the Tenderer's maintenance, repair, spare parts and stocking obligations prescribed in the conditions of Contract and or in the Technical Specifications.</i>
7.	3.14.3 (a) Catalogues, Manufacturer's Drawings	<p><i>i) A detailed description of the essential technical and performance characteristics of the goods whether in brochures, catalogues, drawings or otherwise,</i></p> <p><i>ii) A list giving full particulars, including available source and current prices of spare parts, special tools and other incidental apparatus necessary for the proper and continuing functioning of the goods for a minimum period of three (3) years, following commencement of the use of the goods by Kenya Power, and,</i></p> <p><i>iii) Duly completed Schedule of Guaranteed Technical Particulars (GTP) as per Tender Specifications demonstrating substantial responsiveness of the goods and service to those specifications and, if any, a statement of deviations and exceptions to the provisions of the Technical Specifications.</i></p>
8.	3.15.1 Sample(s)	<i>These are not a requirement in this tender</i>
9.	3.16.2 Warranty – Period of	<i>As indicated in Section XIX- Technical Specifications</i>
10.	3.17.1 Tender Security	<i>The tender security shall be one percent (1%) of the total tender price offered. However the Original Tender Security in an envelope clearly labeled with the tender number & name, shall be deposited in the Tender Security Box on 3rd Floor Supply Chain Reception on or before the opening date.</i>
11.	3.34.2 Award of Contract	<i>The award shall be made on item by item basis</i>
12.	3.21 Number of Sets of and Tender Format	<i>There will only be one document submitted on the e-procurement portal. Bidders shall ensure that they upload all the required documents into the portal.</i>
13.	3.22 Preparation and Signing of the Tender	<i>There will only be one document submitted on the e-procurement portal. Bidders shall ensure that they upload all the required documents into the portal.</i>
14.	3.23 Sealing and Outer Marking of Tenders	<i>For purposes of this tender, this is not applicable as the tender is being submitted electronically, however the Original Tender Security should be kept in a clearly labeled envelope and deposited in the Tender Security Box on 3rd Floor Supply Chain Reception on or before the opening date.</i>

15.	3.26 Opening of Tenders	<i>The tender shall be opened electronically at Stima Plaza Auditorium at 10.30 a.m. and bidders are encouraged to participate.</i>
-----	--------------------------------	---

SECTION IV - SCHEDULE OF REQUIREMENTS

Part A - Brief Schedule Of Details On Goods Required

For Supply of Motor Vehicles, Motor Cycle & Plant - KP3/9A/OT/02/17-18.

	<u>KPLC Specifications</u>	<u>Description</u>	<u>Qty</u>	<u>Drawing No.</u>
1	KPLC-TPT-01-17-18	Heavy Duty, Utility passenger vehicle, 4x4, LWB, 2400cc-3000cc, Diesel	2	
2	KPLC-TPT-02-17-18	Light truck, 4x2, 4.0-5.0 Ton, Low sided body (Street lighting bucket).	15	S.K No.09366 Sheet G/1
3	KPLC-TPT-03-17-18	Hydraulic high lift platform (street light bucket) on light truck.	10	
4	KPLC-TPT-04-17-18	Medium truck, 7-8 Ton, 4x2, cab chassis with low sided body.	15	S.K No.09366 Sheet C2
5	KPLC-TPT-05-17-18	11.0 Ton Truck Mounted Lifting crane, 110 kNm capable of lifting 6.0 ton, complete with Augur.	15	S.K No.09366 Sheet J2
6	KPLC-TPT-06-17-18	5.0 Ton Lifting Capacity Forklift	2	
7	KPLC-TPT-07-17-18	8.0 Ton Lifting Capacity Forklift.	1	
8	KPLC-TPT-08-17-18	3 Wheel logger-loader.	3	
9	KPLC-TPT-09-17-18	Prime mover complete with semi-trailer (logging trailer).	1	
10	KPLC-TPT-10-17-18	3.5 Ton truck logging lifting crane complete with hook and grapple.	1	
11	KPLC-TPT-11-17-18	Motor cycle, Trail, 120cc-130cc	112	

***NOTES:-**

1. All Tenderers must indicate the type, model (where applicable), dimensions and weight of the goods in their bid documents.
2. Tenderers shall, where applicable, indicate ready stocks and quantity if available.
3. All deliveries shall be made to KPLC Transport depot in Ruaraka, Nairobi.
4. These goods will be delivered according to the delivery schedule in the Order (LPO).

SECTION V - PRICE SCHEDULE FOR GOODS*(TENDERER MUST INDICATE THE CURRENCY OF THE OFFER PRICE)*

No.	KPLC Specifications	Description	Qty	Country of Origin	Unit price DDP Kshs (VAT Exclusive)	Unit price DDP Kshs (VAT Inclusive)	Total price DDP Kshs (VAT Inclusive)
1	KPLC-TPT-01-17-18	Heavy Duty, Utility passenger vehicle, 4x4, LWB, 2400cc-3000cc, Diesel	2				
2	KPLC-TPT-02-17-18	Light truck, 4x2, 4.0-5.0 Ton, Low sided body (Street lighting bucket).	15				
3	KPLC-TPT-03-17-18	Hydraulic high lift platform (street light bucket) on light truck.	10				
4	KPLC-TPT-04-17-18	Medium truck, 7-8 Ton, 4x2, cab chassis with low sided body.	15				
5	KPLC-TPT-05-17-18	11.0 Ton Truck Mounted Lifting crane, 110 kNm capable of lifting 6.0 ton, complete with Augur.	15				
6	KPLC-TPT-06-17-18	5.0 Ton Lifting Capacity Forklift	2				
7	KPLC-TPT-07-17-18	8.0 Ton Lifting Capacity Forklift.	1				
8	KPLC-TPT-08-17-18	3 Wheel logger-loader.	3				

9	KPLC-TPT-09-17-18	Prime mover complete with semi-trailer (logging trailer).	1				
10	KPLC-TPT-10-17-18	3.5 Ton truck logging lifting crane complete with hook and grabble.	1				
11	KPLC-TPT-11-17-18	Motor cycle, Trail, 120cc-130cc	112				

Name of Tenderer

Name and Capacity of authorised person signing the Tender

Signature of authorised person signing the Tender

Stamp of Tenderer and date

***NOTES:-**

1. The offered unit price MUST be rounded to two decimal places. Where the Tenderer fails to round the offered unit price as required, then, the offered unit price shall be rounded downwards to two decimal places and used for the purposes of this tender.

Part C- COST BREAKDOWN

ITEM DESCRIPTION	KSH. CLEARLY SEPAPARTE THE VATABLE & NON VATABLE ITEMS
MAKE OFFERED	
MODEL OFFERED	
VATABLE ITEMS	
UNIT PRICE - VATABLE	
CONSTRUCTION & PAINTING	
OTHER REQUIREMENTS	
ANY OTHER VATABLE COST	
VAT 16%	
TOTAL PRICE PER UNIT - VATABLE	
NON-VATABLE ITEMS	
1. UNIT PRICE-NON VATABLE	
2. REGISTRATION EXPENSES	
3. ADVANCE TAX	
4. ANY OTHER NON-VAVABLE COST	

SECTION VI - EVALUATION CRITERIA

Evaluation of duly submitted tenders will be conducted along the following stages: -

6.1 Part 1 - Preliminary Evaluation Criteria Under Paragraph 3.28 of the ITT. These are mandatory requirements. This shall include confirmation of the following: -

6.1.1 *Submission of Tender Security - Checking its validity, whether it is Original; whether it is issued by a local bank/institution; whether it is strictly in the format required in accordance with the sample Tender Security Form(s).*

6.1.2 *Submission of Declaration Form(s) duly completed and signed.*

6.1.3 *Submission and considering Tender Form duly completed and signed.*

6.1.4 *Submission and considering the following:-*

6.1.4.1 *For Local Tenderers*

- a) *Company or Firm's Registration Certificate*
- b) *PIN Certificate.*
- c) *Valid Tax Compliance Certificate.*
- d) *Names with full contact as well as physical addresses of previous customers of similar goods and reference letters from at least four (4) previous customers.*

6.1.4.2 *For Foreign Tenderers*

- a) *Company or Firm's Registration Certificate*
- b) *PIN Certificate or its equivalent in the country of bidder or a statement from the tax authorities in the Tenderer's country of origin indicating that such certificate or its equivalent is not issued.*
- c) *Valid Tax Compliance Certificate or its equivalent in the country of bidder or a statement from the tax authorities in the Tenderer's country of origin indicating that such certificate or its equivalent is not issued.*
- d) *Names with full contact as well as physical addresses of previous customers of similar goods and reference letters from at least four (4) previous customers.*

6.1.5 *That the Tender is valid for the period required.*

6.1.6 *Submission and considering the Confidential Business Questionnaire:-*

- a) *Is fully filled.*
- b) *That details correspond to the related information in the bid.*
- c) *That the Tenderer is not ineligible as per paragraph 3.2 of the ITT.*

6.1.7 *Submission and considering the Certificate of Confirmation of Directors (CR12)*

- 6.1.8 *Submission of Copies of relevant Type Test Certificates and their Reports or Test Certificate and their Reports from the designated bodies.*
- 6.1.9 *Submission of a copy of accreditation certificate for the testing body to ISO/ IEC 17025.*
- 6.1.10 *Submission of a copy of:-*
- a) *the Manufacturer's valid quality management system certification i.e. ISO 9001 for goods from outside Kenya.*
 - b) *valid KEBS Mark of Quality Certificate or KEBS Standardisation Mark Certificate for goods manufactured in Kenya.*
- 6.1.11 *If required in the Tender Document, submission of the following-*
- a) *Samples*
 - b) *Catalogues and/or Manufacturer's Drawings*
 - c) *Schedule of Guaranteed Technical Particulars as per tender specifications.*
- 6.1.12 *Record of unsatisfactory or default in performance obligations in any contract shall be considered. This shall include any Tenderer with unresolved case(s) in its performance obligations for more than two (2) months in any contract.*
- 6.1.13 *Notwithstanding the above, considering any outstanding orders/Supplier Performance Review Scheme (SPRS) where applicable and the production capacity indicated by the Tenderer.*

Tenders will proceed to the Technical Stage only if they qualify in compliance with Part 1 above, Preliminary Evaluation under Paragraph 3.28.

6.2 Part II - Technical Evaluation Criteria Under Paragraph 3.30 of the ITT.

OPTION II : NON-SCORING METHOD

- 6.2.1 Evaluation of the following technical information against Tender Requirements and Specifications:-
- 6.2.1.1 *For goods manufactured outside Kenya, applicable relevant valid ISO 9001 certification*
 - 6.2.1.2 *For goods manufactured in Kenya - valid KEBS Mark of Quality Certificate or KEBS Standardisation Mark Certificate*
 - 6.2.1.3 *Type Test Certificates and their Reports or Test Certificates and their Reports from the designated bodies for full compliance with Tender Specifications*
 - 6.2.1.4 *The accreditation certificate for the testing laboratory to ISO/ IEC 17025.*
 - 6.2.1.5 *Manufacturer's Authorization*
 - 6.2.1.6 *As contained in the following documents –*
 - a) *Manufacturer's Warranty*
 - b) *Catalogues and or Manufacturer's drawings*
 - c) *Schedule of Guaranteed Technical Particulars as per Technical Specifications.*

Tenders will proceed to the Detailed Technical Stage only if they qualify in compliance with Part II clause 6.2.1 above, Preliminary Evaluation under Paragraph 3.28.

6.2.2 Detailed Technical Evaluation

- a) *The Schedule of Guaranteed Technical Particulars (GTP) shall be evaluated against Tender Specifications to confirm compliance of the goods and services to the specifications and evaluation of any deviations and exceptions declared by the Tenderer.*
- b) *Evaluation of compliance of submitted samples (where required) to technical specifications.*
- c) *Identifying and determining any deviation(s) from the requirements; errors and oversights.*

Tenderers will proceed to Financial Evaluation stage only if they qualify in compliance with Parts I and II i.e. Preliminary and Technical stages.

6.3 Part III – Financial Evaluation Criteria Under Paragraph 3.31 of the ITT. These are mandatory requirements.

6.3.1 This will include the following: -

- a) *Confirmation of the authenticity and sufficiency of the submitted Tender Security.*
- b) *Confirmation of and considering Price Schedule duly completed and signed.*
- c) *Checking that the Tenderer has quoted prices based on Delivery Duty Paid (DDP) terms,*
- d)* *Checking submission of audited financial statements required which must be those that are reported within eighteen (18) calendar months of the date of the tender document.*
- e) *Conducting a financial comparison, including conversion of tender currencies into one common currency,*
- f) *Taking into account the cost of any deviation(s) from the tender requirements,*
- g) *Considering information submitted in the Confidential Business Questionnaire against other information in the bid including:-*
 - i) *Declared maximum value of business*
 - ii) *Shareholding and citizenship for preferences where applicable.*
- h) *Apply Exclusive margin of preference, where applicable as per Clause 3.32 of the tender document*

6.3.2 Confirming the following: -

6.3.2.1 that the Supplier's offered Delivery Schedule meets KPLC's requirements.

TENDER FOR SUPPLY OF MOTOR VEHICLES, MOTOR CYCLES & PLANT- AUGUST 2017

6.3.2.2 that the Supplier's offered Terms of Payment meets KPLC's requirements.

6.4 The Successful Tenderer shall be the one with the lowest evaluated price.

***NOTES: -**

1. For purposes of evaluation, the exchange rate to be used for currency conversion shall be the selling exchange rate ruling on the date of tender closing provided by the Central Bank of Kenya. (Visit the Central Bank of Kenya website).
2. Total tender value means the Tenderer's total tender price inclusive of Value Added Tax (V.A.T) for the goods it offers to supply.
2. For companies or firms that are registered or incorporated within the last one calendar year of the Date of the Tender Document, they should submit certified copies of bank statements covering a period of at least six months prior to the date of the tender document. The copies should be certified by the Bank issuing the statements. The certification should be original.

TABLE OF CLAUSES ON GENERAL CONDITIONS OF CONTRACT

Clause No.	Headings	Page No.
7.1	Definitions.....	36
7.2	Application.....	36
7.3	Country of Origin.....	37
7.4	Standards.....	37
7.5	Supplier Performance Rating Scheme.....	37
7.6	Use of Contract Documents and Information.....	37
7.7	Patent Rights.....	38
7.8	Performance Security.....	38
7.9	Approval Before Manufacture.....	39
7.10	Inspections and Tests.....	39
7.11	Pre – Shipment Verification of Conformity.....	40
7.12	Packaging and Labelling	40
7.13	Delivery and Documents for Goods on DDP Terms.....	41
7.14	Consignment.....	41
7.15	Transportation.....	41
7.16	Insurance	42
7.17	Payment.....	42
7.18	Interest.....	43
7.19	Prices.....	43
7.20	Variation of Contract.....	43
7.21	Assignment.....	44
7.22	Sub-Contracts.....	44
7.23	Termination of Contract.....	44
7.24	Liquidated Damages.....	45
7.25	Warranty.....	45
7.26	Resolution of Disputes	45
7.27	Language and Law.....	46
7.28	Force Majeure.....	46

SECTION VII – GENERAL CONDITIONS OF CONTRACT

The General Conditions of Contract *hereinafter referred abbreviated as the GCC* shall form part of the Conditions of Contract in accordance with the law and KPLC’s guidelines, practices, procedures and working circumstances. The provisions in the GCC will apply unless an alternative solution or amendment is made under other parts of the Contract including the Special Conditions of Contract.

7.1 Definitions

In this contract, the following terms shall be interpreted as follows: -

- a) *“Day” means calendar day and “month” means calendar month.*
- b) *“The Contract” means the agreements entered into between KPLC and the Supplier, as recorded in the Contract Form signed by the parties, including all attachments and appendices thereto and all documents incorporated by reference therein.*
- c) *“The Contract Price” means the price payable to the Supplier under the contract for the full and proper performance of its contractual obligations.*
- d) *“The Goods” includes all of the equipment, machinery, and or other materials, which the Supplier is required to supply to KPLC under the contract.*
- e) *“The Procuring Entity” means The Kenya Power and Lighting Company Limited or its successor(s) and assign(s) where the context so admits (hereinafter abbreviated as KPLC).*
- f) *“The Supplier” means the individual or firm supplying the goods under this contract or his/ her/ its permitted heir(s), personal representative(s), successor(s) or permitted assign(s) where the context so admits. For the avoidance of doubt this shall mean the successful Tenderer(s) pursuant to the tender.*
- g) *Wherever used in the contract, “delivery” shall be complete or be deemed to be complete, unless the circumstances indicate otherwise, when the goods have been inspected and tested in accordance with the Contract and where KPLC does not signify its approval to the Supplier, but retains the goods without giving notice of rejection, on the expiration of thirty (30) days from date of documented receipt by the duly authorized representative of KPLC, of the goods, at KPLC stores or other indicated site.*
- h) *Supplier Rating Performance Scheme (SPRS) means the annual continuous evaluation of the Supplier’s performance of the contract based on the parameters of timely delivery, quality of goods, frequency of communication, timely response, innovation, dispute resolution.*

7.2 Application

These General Conditions shall apply to the extent that provisions of other parts of the contract do not supersede them.

7.3 Country of Origin

- 7.3.1 For purposes of this clause, “Origin” means the place where the goods were mined, grown, or produced.
- 7.3.2 The origin of Goods and Services is distinct from the nationality of the Supplier.

7.4 Standards

The Goods supplied under this contract shall conform to the standards mentioned in the Technical Specifications.

7.5 Supplier Performance Rating Scheme

- 7.5.1 KPLC shall use a Supplier Performance Rating Scheme (SPRS) to measure the annual performance of the Supplier’s obligations and its conduct of the contract.
- 7.5.2 The Scheme will be updated periodically commencing with the date of execution of the contract by both parties. KPLC shall provide the Supplier with a copy of the SPRS report.
- 7.5.3 KPLC shall consider the Supplier’s overall performance at the end of the performance period.
- 7.5.4 At the request of either party, the parties shall discuss and conclude deliberations on the annual SPRS report. At any such meetings and/or for the purposes of the deliberations, KPLC Supply Chain – Procurement Department shall appoint the Chairperson as well as the Secretariat.
- 7.5.5 The SPRS measures shall be according to Supplier Performance Rating Form in Section XXVI
- 7.5.6 A KP1, KP2 & KP3 assessment of the Supplier on the SPRS will be a consideration for continued engagement between the parties in the subsequent year. A KP4 assessment of the Supplier shall be a termination event.

7.6 Use of Contract Documents and Information

- 7.6.1 The Supplier shall not, without KPLC’s prior written consent, disclose the contract, or any provision thereof or any specification, plan, drawing, pattern, sample, or information furnished by or on behalf of KPLC in connection therewith, to any person other than a person employed by the Supplier in the performance of the contract.
- 7.6.2 The Supplier shall not, without KPLC’s prior written consent, make use of any document or information enumerated in clause 7.5.1 above.
- 7.6.3 Any document, other than the contract itself, enumerated in clause 7.5.1 shall remain the property of KPLC and shall be returned (including all copies) to KPLC on completion of the Supplier’s performance under the contract if so required by KPLC.

7.7 Patent Rights

The Supplier shall indemnify KPLC against all third party claims of infringement of patent, trademark, or industrial design rights arising from use of the goods of any part thereof in KPLC’s country.

7.8 Performance Security

- 7.8.1 Within fourteen (14) days of the date of the notification of contract award, the Supplier shall furnish to KPLC the Performance Security which shall be either one or a combination of the following:-
- a) an original Bank Guarantee that is strictly in the form and content as prescribed in the Performance Security Form (Bank Guarantee) in the Tender Document.
 - b) Confirmed Standby Letters of Credit (LC). All costs, expenses and charges levied by all banks party to the LC including confirmation charges shall be prepaid by the successful Tenderer. Certain mandatory conditions of the LC shall be as prescribed in the Performance Security Form (LC) in the Tender Document.
- 7.8.2 The Performance Security shall be issued by a commercial bank licensed by the Central Bank of Kenya. The bank must be located in Kenya.
- 7.8.3 The Performance Security shall be the sum of ten percent (10%) of the contract price. It shall be in the currency of the contract price.
- 7.8.4 Failure of the Supplier to furnish the Performance Security, the award shall be annulled and the Tender Security forfeited, in which event KPLC may notify the next lowest evaluated Tenderer that its Tender has been accepted.
- 7.8.5 The proceeds of the Performance Security shall be payable to KPLC as compensation for any loss resulting from the Supplier's failure to comply with its obligations in accordance with the contract without KPLC being required to demonstrate the loss it has suffered.
- 7.8.6 The Performance Security shall be valid for a minimum of sixty (60) days after satisfactory delivery for both Foreign and Local Suppliers.
- 7.8.7 KPLC shall seek authentication of the Performance Security from the issuing bank. It is the responsibility of the Supplier to sensitize its issuing bank on the need to respond directly and expeditiously to queries from KPLC. The period for response shall not exceed five (5) days from the date of KPLC's query. Should there be no conclusive response by the Bank within this period, such Supplier's Performance Security may be deemed as invalid and the Contract nullified, unless information to the contrary is received by KPLC two (2) days before the expiry of the Supplier's Tender Security.
- 7.8.8 Subject to the provisions of this contract, the Performance Security will be discharged by KPLC and returned to the Supplier not earlier than sixty (60) days following the date of completion of the Supplier's obligations under the contract, including any warranty obligations, under the contract.

7.9 Approval Before Manufacture

- 7.9.1 All technical details and design drawings for the items to be supplied shall be submitted by the Supplier to KPLC for approval before manufacture.
- 7.9.2 Should the Supplier fail to observe this condition of approval before manufacture, KPLC may decline to accept the goods, or the Supplier shall either replace them or make alterations necessary, but in any case, KPLC shall incur no liability howsoever.

7.10 Inspection and Tests

- 7.10.1 KPLC or its representative shall have the right to inspect and/or to test the goods to confirm their conformity to the contract specifications. KPLC shall notify the Supplier in writing in a timely manner, of the identity of any representative(s) retained for these purposes.
- 7.10.2 Prior to the manufacture or production of the goods on order, KPLC reserves the right to inspect the manufacturing or production facility and the quality management system. The manufacturer or producer shall meet the cost of routine inspection while KPLC shall meet the cost of air travel to the nearest airport and accommodation of two of its nominated officers inspecting and witnessing tests.
- 7.10.3 It is the responsibility of the Supplier to confirm if this right is to be exercised. Such visit and or inspection shall in no way prejudice KPLC's rights and privileges.
- 7.10.4 Upon completion of manufacturing or production process, KPLC reserves the right to send two of its nominated officers to inspect the goods on order at the place of manufacture where inspection and acceptance tests as per tender specifications shall be carried out in their presence. Tests shall be done in accordance with the test standard(s) given in the Technical Specification of the goods on order.
- 7.10.5 The manufacturer or producer shall meet the cost of tests as per tender specifications while KPLC shall meet the cost of air travel to the nearest airport and accommodation of its two nominated officers inspecting and witnessing the tests.
- 7.10.6 The inspections and tests may be conducted on the premises of the Supplier or its subcontractor(s), at point of production, manufacture, delivery and or at the goods' final destination. If conducted on the premises of the Supplier or its subcontractor(s), all reasonable facilities and assistance, including access to drawings and production data, shall be furnished to the inspectors at no charge to KPLC. In all cases, the equipment used for tests must be validly calibrated by the national standards body and a copy of the calibration certificate(s) must be submitted with the test report(s).
- 7.10.7 Complete test report(s) for all the goods as per Tender Specifications shall be submitted to KPLC for approval before packaging and shipment. No material or goods shall be shipped or delivered without written approval from KPLC.
- 7.10.8 Should any inspected or tested goods fail to conform to the specifications, KPLC shall reject the goods, and the Supplier shall either replace the rejected goods or make alterations necessary to meet specification requirements free of cost to KPLC. The period for replacement or alterations together with delivery to KPLC shall be fourteen (14) days or as may otherwise be specified in the notice of rejection.
- 7.10.9 The Supplier shall collect the rejected goods within fourteen (14) days from the date of notification of rejection. If the rejected goods are not collected within this period, the goods will be disposed of by KPLC guided by the Disposal of Uncollected Goods Act, Chapter 38 of the Laws of Kenya.
- 7.10.10 Notwithstanding any previous inspection(s) and test(s) KPLC shall inspect and may test the goods upon arrival at the indicated site. Where KPLC inspects and rejects the goods after the

goods arrival, KPLC shall claim from the Supplier any incidental costs incurred in relation thereof.

- 7.10.11 KPLC's right to inspect, test and where necessary, reject the goods after their arrival shall in no way be limited or waived by reason of the goods having previously been inspected, tested and passed by KPLC or its representative(s) prior to the goods delivery.
- 7.10.12 For the avoidance of doubt, any acknowledgement by KPLC on the Supplier's or sub-contractor's document shall not be conclusive proof or evidence of satisfactory delivery without duly authorized approval by KPLC.
- 7.10.13 Nothing in clause 7.10 shall in any way release the Supplier from any warranty or other obligations under this Contract.

7.11 Pre-Shipment Verification of Conformity (PVoC)

- 7.11.1 All Suppliers of imported goods and or products must obtain a Certificate of Conformity issued by an authorized KEBS appointed partner prior to shipment.
- 7.11.2 The Certificate is a mandatory customs clearance document in Kenya. KEBS has appointed a number of Inspection Bodies to perform the PVoC programme on their behalf depending on the country of supply origin. The cost of pre-shipment verification shall be borne by the Supplier.

Full information on authorized inspection bodies should be obtained from KEBS.

7.12 Packaging and Labelling

- 7.12.1 The Supplier shall provide such packaging of the goods as is required to prevent their damage or deterioration during transit to their final destination, as indicated in the contract.
- 7.12.2 The method of packaging, labeling and marking shall comply strictly with such special requirements as shall be specified and attached to the Tender and particular Order.
- 7.12.3 The labelling, marking and documentation within and outside the packages shall comply strictly with such special requirements as shall be expressly provided for in the contract.
- 7.12.4 The goods shall be packed in good condition suitable for sea/air/road/rail dispatch. Hazard in transit to the final destination shall include rough handling and storage in tropical conditions.
- 7.12.5 The Supplier shall enclose a packing list in each package and all documents relating to the Order shall show the Stores Code Number detailed against the items.
- 7.12.6 The Supplier shall ensure that all cases or packages shall be marked (painted) with bright pink bands five (5) inches in width so as to form a diagonal cross on

every face. All bundles and pieces must bear a conspicuous bright pink colour mark to ensure identification in any position in which they may appear on un-loading.

- 7.12.7 The Supplier shall ensure that all lettering shall be no less than seven decimal five centimeters (7.5cm) or three inches (3") high.

7.13 Delivery and Documents for Goods on Delivered Duty Paid (DDP) Terms.

- 7.13.1 Delivery of the goods shall be made by the Supplier to the place and in accordance with the terms specified by KPLC in its Schedule of Requirements.
- 7.13.2 The Supplier shall notify KPLC of the full details of the delivered goods by delivering together with the goods a full set of the following documents:-
- a) Supplier's invoice showing the goods description, quantity, unit price and total price,
 - b) Delivery note for every consignment originating from the party contracted by KPLC. The Delivery Note should be serialized, dated and contain the number of the Official Purchase Order,
 - c) Copy of the Certificate of Conformity (CoC),
 - d) Manufacturer's warranty certificate and
 - e) Packing list identifying contents of each package which list should include casing number, full description of the items and the quantities in each package.
- 7.13.3 It is the responsibility of the Supplier to ensure that the delivery documents are received by KPLC at the designated delivery point at the time of delivery.
- 7.13.4 Any late or non-submission of the delivery documents shall be treated as part of non-performance on the part of the Supplier and KPLC shall be entitled to call up the Performance Security.
- 7.13.5 The Supplier should notify KPLC in writing of its intention to deliver goods fourteen (14) days prior to delivery, and a further confirmation two (2) working days before actual delivery to the designated delivery point.

7.14 Consignment

- 7.14.1 The terms shall be strictly on Delivered and Duty Paid (DDP) basis.
- 7.14.2 The Consignee shall be the supplier or supplier's agent whose responsibilities shall include payment of all Customs taxes, duties and levies, clearance of the goods, and delivery to KPLC stores. For avoidance of doubt, this includes Value Added Tax (VAT), Railway Development Levy (RDL) and Import Duties.

7.15 Transportation

- 7.15.1 The Supplier shall be required to meet all transport expenses until delivery.

7.16 Insurance

- 7.16.1 The Supplier shall (except in respect to losses, injuries or damage resulting from any act or neglect of KPLC) indemnify and keep indemnified KPLC against all losses and claims for injuries or damage to any person or property whatsoever which may arise out of or in consequence of the contract and against all claims, demands, proceedings, damages, costs, charges, and expenses whatsoever in respect thereof or in relation thereto.

7.17 Payment

- 7.17.1 Payments shall be made promptly by KPLC thirty (30) days from delivery and submission of invoice together with other required and related documents or as otherwise prescribed in the contract.
- 7.17.2 The credit period shall be thirty (30) days from satisfactory delivery and submission of invoice together with other required and related documents.
- 7.17.3 Upon satisfactory delivery and submission of invoice together with other required and related documents, KPLC shall pay for the goods after the credit period.
- 7.17.4 Payment shall primarily be through KPLC's cheque or Real Time Gross Settlement (RTGS) for local based suppliers or Telegraphic Transfer (TT) for foreign based suppliers.
- 7.17.5 Suppliers who are to be paid through RTGS or TT must ensure that they submit the following:
- a) invoice containing the Bank's Name and Branch,
 - b) Name/Title of Bank account,
 - c) Bank account number
 - d) SWIFT CODE.
 - e) A letter signed by the authorized signatory of the bank account of the Tenderer confirming details (a) to (d) above. This letter must contain the name of that authorized signatory and a Board Resolution that is sealed.
- 7.17.6 Where applicable, a copy of a valid Performance Security, stamped, certified as authentic by KPLC, shall form part of the documents to be presented to KPLC before any payment is made.
- 7.17.7 The terms shall be strictly on Delivered and Duty Paid (DDP).
- 7.17.8 Suppliers who request for a Letter of Credit (*hereinafter abbreviated as LC*) –
- a) *shall submit proforma invoices containing the advising Bank's Name and Branch, Name/Title of Bank account, Bank account number and the SWIFT CODE; where required, proposed confirming bank; LC validity period and any other details that may be required to facilitate this process.*
 - b) *Shall meet all the LC bank charges levied by both its bank and KPLC's bank as well as any other bank that is a party to the LC.*
 - c) *Any extension and or amendment charges and any other costs that may result from the Supplier's delays, requests, mistakes or occasioned howsoever by the Supplier shall be to the Beneficiary's account.*
 - d) *The maximum number of extensions and amendments shall be limited to two (2).*
 - e) *Notwithstanding sub-clause 7.18.6 (a), should the Supplier require a confirmed LC, then all confirmation and any other related charges levied by both the Supplier's and KPLC's bank as well as any other bank party to such confirmation shall be to the Beneficiary's account.*
 - f) *LCs shall be -*
 - (i.) *partial for partial performance*

- (ii.) *opened only for the specific deliveries in accordance with the delivery schedule indicated in the Official Purchase Order or any formal note amending that Order.*
 - (iii.) *revolving subject to the maximum annual value of total quantity indicated in the Official Purchase Order*
 - (iv.) *without prejudice to any other provision of the contract, valid for a maximum period of one year.*
 - g) *The Supplier shall be required to submit a proforma invoice for each lot for use in the placement of order and opening of the LC. The proforma invoice shall be on total DDP basis.*
 - h) *A copy of the Performance Security, stamped and certified as authentic by KPLC, whose expiry date should not be less than sixty (60) days from the LC expiry date, shall form part of the documents to be presented to the Bank before any payment is effected.*
- 7.17.9 KPLC shall have the sole discretion to accept or decline any Supplier's payment request through Letters of Credit without giving any reason for such decline.

7.18 Interest

Interest payment by KPLC is inapplicable in the contract.

7.19 Prices

- 7.19.1 Subject to clause 7.20 herein-below, prices charged by the Supplier for goods delivered and services performed under the contract shall, be fixed for the period of the contract with no variations.

7.20 Variation of Contract

KPLC and the Supplier may vary the contract only in accordance with the following: -

- a) *the quantity variation for goods shall not exceed ten percent (15%) of the original contract quantity.*
- b) *The cumulative value variation shall not exceed twenty five percent (25%) of the original contract value.*
- c) *the quantity variation must be executed within the period of the contract.*

7.21 Assignment

The Supplier shall not assign in whole or in part its obligations to perform under this contract, except with KPLC's prior written consent.

7.22.1 Subcontracts

- 7.22.1 The Supplier shall notify KPLC in writing of all subcontracts awards under this contract if not already specified in the tender. Such notification, in the original tender or obligation under the Contract shall not relieve the Supplier from any liability or obligation under the Contract.
- 7.22.2 In the event that an award is given and the contract is sub contracted, the responsibility and onus over the contract shall rest on the Supplier who was awarded.

7.23 Termination of Contract

- 7.23.1 KPLC may, without prejudice to any other remedy for breach of contract, by written notice sent to the Supplier, terminate this contract in whole or in part due to any of the following: -
- a) *if the Supplier fails to deliver any or all of the goods within the period(s) specified in the contract, or within any extension thereof granted by KPLC.*
 - b) *if the Supplier fails to perform any other obligation(s) under the contract.*
 - c) *if the Supplier, in the judgment of KPLC has engaged in corrupt or fraudulent practices in competing for or in executing the contract.*
 - d) *by an act of force majeure.*
 - e) *if the Supplier becomes insolvent or bankrupt*
 - f) *if the Supplier has a receiving order issued against it, compounds with its creditors, or an order is made for its winding up (except for the purposes of its amalgamation or reconstruction), or a receiver is appointed over its or any part of its undertaking or assets, or if the Supplier suffers any other analogous action in consequence of debt.*
 - g) *if the Supplier abandons or repudiates the Contract.*
- 7.23.2 KPLC by written notice sent to the Supplier may terminate the Contract in whole or in part, at any time for its convenience. The notice of termination shall specify that the termination is for KPLC's convenience, the extent to which performance, by the Contractor, of the Contract, is terminated and the date on which such termination becomes effective.
- 7.23.3 For the remaining part of the Contract after termination for convenience, KPLC may pay to the Supplier an agreed amount for partially completed satisfactory deliveries.
- 7.23.4 In the event that KPLC terminates the contract in whole or in part, it may procure, upon such terms and in such manner as it deems appropriate, goods similar to those undelivered or not rendered, and the Supplier shall be liable to KPLC for any excess costs for such similar goods and or any other loss PROVIDED that the Supplier shall not be so liable where the termination is for convenience of KPLC.
- 7.23.5 The Parties may terminate the Contract by reason of an act of *force majeure* as provided for in the contract.
- 7.23.6 The Contract may automatically terminate by reason of an act of *force majeure* as provided for in the Contract.

7.24 Liquidated Damages

Notwithstanding and without prejudice to any other provisions of the contract, if the Supplier fails to deliver any or all of the goods within the period specified in the contract, KPLC shall, without prejudice to its other remedies under the contract, deduct from the contract prices, liquidated damages sum equivalent to

0.5% of the delivered or shipment price (whichever is applicable) per day of delay of the delayed items up to a maximum of ten percent (10%) of the delivered price of the delayed goods.

7.25 Warranty

7.25.1 The Supplier warrants that the goods supplied under the contract are new, unused, of the most recent or current specification and incorporate all recent improvements in design and materials unless provided otherwise in the contract. The Supplier further warrants that the goods supplied under this contract shall have no defect arising from manufacture, materials or workmanship or from any act or omission of the Supplier that may develop under normal use of the supplied goods under the conditions obtaining in Kenya.

7.25.2 This warranty will remain valid for the period indicated in the special conditions of contract after the goods, or any portion thereof as the case may be, have been delivered to the final destination indicated in the contract.

7.25.3 KPLC shall promptly notify the Supplier in writing of any claims arising under this warranty.

7.25.4 Upon receipt of such a notice, the Supplier shall, with all reasonable speed, replace the defective goods without cost to KPLC.

7.25.5 If the Supplier having been notified, fails to remedy the defect(s) within a reasonable period, KPLC may proceed to take such remedial action as may be necessary, at the Supplier's risk and expense and without prejudice to any other rights which KPLC may have against the Supplier under the contract.

7.26 Resolution of Disputes

7.26.1 KPLC and the Supplier may make every effort to resolve amicably by direct informal negotiation any disagreement or dispute arising between them under or in connection with the contract.

7.26.2 If, after thirty (30) days from the commencement of such informal negotiations both parties have been unable to resolve amicably a contract dispute, either party may resort to resolution before a recognized local forum for the resolution of disputes.

7.27 Language and Law

The language of the contract and the law governing the contract shall be the English language and the laws of Kenya respectively unless otherwise stated.

7.27 Waiver

Any omission or failure by KPLC to exercise any of its rights or enforce any of the penalties arising from the obligations imposed on the Supplier shall in no way, manner or otherwise howsoever, alter, amend, prejudice, vary, waive or be deemed to alter, amend, prejudice, vary, waive or otherwise whatsoever any of KPLC's powers and rights as expressly provided in and as regards this contract.

7.28 Force Majeure

7.28.1 *Force majeure* means any circumstances beyond the control of the parties, including but not limited to: -

- a) *war and other hostilities (whether war be declared or not), invasion, act of foreign enemies, mobilization, requisition or embargo;*
- b) *ionizing radiation or contamination by radio-activity from any nuclear fuel or from any nuclear waste from the combustion of nuclear fuel, radioactive toxic explosives or other hazardous properties of any explosive nuclear assembly or nuclear components thereof;*
- c) *rebellion, revolution, insurrection, military or usurped power and civil war;*
- d) *riot, commotion or disorder except where solely restricted to employees servants or agents of the parties;*
- e) *un-navigable storm or tempest at sea.*

7.28.2 Notwithstanding the provisions of the contract, neither party shall be considered to be in default or in breach of its obligations under the contract to the extent that performance of such obligations is prevented by any circumstances of *force majeure* which arise after the Contract is entered into by the parties.

7.28.3 If either party considers that any circumstances of *force majeure* are occurring or have occurred which may affect performance of its obligations it shall promptly notify the other party and provide reasonable proof of such circumstances.

7.28.4 Upon the occurrence of any circumstances of *force majeure*, the Supplier shall endeavour to continue to perform its obligations under the contract so far as is reasonably practicable. The Supplier shall notify KPLC of the steps it proposes to take including any reasonable alternative means for performance, which is not prevented by *force majeure*. The Supplier shall not take any such steps unless directed so to do by KPLC.

7.28.5 If the Supplier incurs additional costs in complying with KPLC's directions under sub clause 7.28.4, then notwithstanding the provisions of the Contract, the amount thereof shall be agreed upon with KPLC and added to the contract price.

7.28.6 If circumstances of *force majeure* have occurred and shall continue for a period of twenty one (21) days then, notwithstanding that the Supplier may by reason thereof have been granted an extension of time for performance of the contract, either party shall be entitled to serve upon the other seven (7) days' notice to terminate the Contract. If at the expiry of the period of twenty-eight (28) days, *force majeure* shall still continue, the contract shall terminate.

SECTION VIII – SPECIAL CONDITIONS OF CONTRACT

The Special Conditions of Contract *hereinafter abbreviated as SCC* shall form part of the Conditions of Contract. They are made in accordance with the law and KPLC's guidelines, practices, procedures and working circumstances. They shall amend, add to and vary the GCC. The clauses in this section need not therefore, be completed but must be completed by KPLC if any changes to the GCC provisions are deemed necessary. Whenever there is a conflict between the GCC and SCC, the provisions of the SCC shall prevail over those in the GCC.

No.	GCC Reference Clause	Particulars of SCC
1.	7.16.1 Terms of Payment	<i>The credit period shall be thirty (30) days from satisfactory delivery and submission of invoice together with other required and related documents.</i>
2.	7.24.2 Period of Warranty	<i>Warranty period as per specification.</i>

SECTION IX - TENDER FORM

Date:.....

Tender No.....

To:

The Kenya Power & Lighting Company Limited,
 Stima Plaza,
 Kolobot Road, Parklands,
 P.O Box 30099 – 00100,
Nairobi, Kenya.

Ladies and Gentlemen,

1. Having read, examined and understood the Tender Document including all Addenda, the receipt of which is hereby duly acknowledged, we, the undersigned Tenderer, offer to supply, deliver, install and commission (*the latter two where applicable*)
(insert goods description) in accordance and conformity with the said tender document for the sum of*(total tender amount inclusive of all taxes in words and figures)* or such sums as may be ascertained in accordance with the Price Schedule attached herewith and made part of this Tender.
2. We undertake, if our Tender is accepted, to deliver, install and commission the goods in accordance with the delivery schedule specified in the Schedule of Requirements.
3. If our Tender is accepted, we will obtain the performance security of a licensed commercial bank in Kenya in a sum equivalent to ten percent (10%) of the contract price for the due performance of the contract, in the form(s) prescribed by The Kenya Power & Lighting Company Limited.
- 4.* We agree to abide by this Tender for a **period of.....days (Tenderer please indicate validity of your tender)** from the date fixed for tender opening as per the Tender Document, and it shall remain binding upon us and may be accepted at any time before the expiration of that period.
5. This Tender, together with your written acceptance thereof and your notification of award, shall not constitute a contract, between us. The contract shall be formed between us when both parties duly sign the written contract.
6. We understand that you are not bound to accept any Tender you may receive.

Yours sincerely,

Name of Tenderer

Signature of duly authorised person signing the Tender

Name and Designation of duly authorised person signing the Tender

Stamp or Seal of Tenderer

***NOTES:**

1. KPLC requires a validity period of at least ninety (90) days.
2. This form must be duly completed, signed, stamped and/or sealed.

SECTION X – CONFIDENTIAL BUSINESS QUESTIONNAIRE FORM

All Tenderers are requested to give the particulars indicated in Part 1 and either Part 2 (a), 2 (b) or 2 (c) whichever applies to your type of business. Tenderers are advised that it is a serious offence to give false information on this form.

Part 1 – General

Business Name.....

Location of business premises.....

Plot No.Street/ Road

Postal Address Postal Code

Tel No.....

Facsimile.....

Mobile and CDMA No.....

E-mail:.....

Nature of your business

Registration Certificate No.....

Maximum value of business which you can handle at any time KSh.....

Name of your BankersBranch.....

*Names of Tenderer's contact person(s)

Designation of the Tenderer's contact person(s)

Address, Tel, Fax and E-mail of the Tenderer's contact person(s)

.....

.....

Part 2 (a) Sole Proprietor

Your name in full
NationalityCountry of origin

Part 2 (b) Partnership

Give details of partners as follows: -

Names	Nationality	Shares (%)
1.....		
2.....		
3.....		
4.....		
5.....		

Part 2 (c) Registered Company

Private or Public

State the nominal and issued capital of company-

*Nominal in KSh.

*Total Issued KSh.

Give details of all directors as follows

Name	Nationality	Shares (%)
1.....		
2.....		
3.....		
4.....		
5.....		

Name of duly authorized person to sign for and on behalf of the Tenderer

Designation of the duly authorized person.....

Signature of the duly authorized person.....

***NOTES TO THE TENDERERS ON THE QUESTIONNAIRE**

1. *The address and contact person of the Tenderer provided above shall at all times be used for purposes of this tender.*
2. *The details on this Form are essential and compulsory for all Tenderers. **Failure to provide all the information requested shall lead to the Tenderer's disqualification.***
3. *For foreign Tenderers please give the details of nominal and issued share capital in the currency of the country of origin of the Tenderer.*

SECTION XI A - TENDER SECURITY FORM – (BANK GUARANTEE)

(To Be Submitted On Bank’s Letterhead)

Date:

To:

The Kenya Power & Lighting Company Limited,
Stima Plaza,
Kolobot Road, Parklands,
P.O Box 30099 – 00100,
Nairobi, Kenya.

WHEREAS (*name of the Tenderer*) (*hereinafter called “the Tenderer”*) has submitted its Tender dated for the supply, installation and commissioning of..... (*please insert KPLC tender no. and name*) (*hereinafter called “the Tender”*);

KNOW ALL PEOPLE by these presents that **WE**.....ofhaving our registered office at.....(*hereinafter called “the Bank”*), are bound unto The Kenya Power and Lighting Company Limited (*hereinafter called “KPLC” which expression shall where the context so admits include its successors-in-title and assigns*) in the sum of for which payment well and truly to be made to the said KPLC, the Bank binds itself, its successors, and assignees by these presents.

We undertake to pay you, upon your first written demand declaring the Tenderer to be in breach of the tender requirements and without cavil or argument, the entire sum of this guarantee being (*amount of guarantee*) as aforesaid, without you needing to prove or to show grounds or reasons for your demand or the sum specified therein.

This tender guarantee will remain in force up to and including thirty (30) days after the period of tender validity, and any demand in respect thereof should reach the Bank not later than the date below.

This guarantee is valid until theday of.....20.....

EITHER

SEALED with the)
COMMON SEAL)

of the said **BANK**) _____

thisday)
of20....)
))
in the presence of :-)
))
_____)
))
and in the presence of:-)
))
_____)

BANK SEAL

OR

SIGNED by the **DULY AUTHORISED REPRESENTATIVE(S)/ ATTORNEY(S)** of the **BANK**

Name(s) and Designation of duly authorised representative(s)/ attorney(s) of the Bank

Signature(s) of the duly authorised person(s)

NOTES TO TENDERERS AND BANKS

1. *Please note that no material additions, deletions or alterations regarding the contents of this Form shall be made to the Tender Security to be furnished by the Tenderer. If any are made, the Tender Security shall not be accepted and shall be rejected by KPLC. For the avoidance of doubt, such rejection will be treated as non-submission of the Tender Security where such Security is required in the tender.*

2. *It is the responsibility of the Tenderer to sensitize its issuing bank on the need to respond directly and expeditiously to queries from KPLC. The period for response shall not exceed three (3) days from the date of KPLC’s query. Should there be no conclusive response by the Bank within this period, such Tenderer’s Tender Security shall be deemed as invalid and the bid rejected.*

3. *The issuing bank should address its response or communication regarding the bond to KPLC at the following e-mail address – “guarantees@ kplc.co.ke”*

4. *The Tender validity period is ninety (90) days as set out in the Invitation to Tender (at Section I of the Tender document) or as otherwise may be extended by KPLC. Therefore the Tender Security must at all times be valid for at least 30 days beyond the tender validity period.*

SECTION XI B - TENDER SECURITY FORM (SACCO SOCIETY, DEPOSIT TAKING MICRO FINANCE INSTITUTIONS, WOMEN ENTERPRISE FUND & YOUTH ENTERPRISE FUND)

(To Be Submitted On Institutions Letterhead)

Date:

To:

The Kenya Power & Lighting Company Limited,
Stima Plaza,
Kolobot Road, Parklands,
P.O Box 30099 – 00100,
Nairobi, Kenya.

WHEREAS.....(hereinafter called “the Tenderer”) has undertaken, in pursuance of your Tender Number.....(*reference number of the Tender*) and its Tender dated(*insert Tenderer’s date of Tender taken from the Tender Form*) to supply(*description of the Goods*) (hereinafter called “the Contract);

AND WHEREAS it has been stipulated by you in the said Contract that the Tenderer shall furnish you with an Institution’s guarantee by an acceptable Institution for the sum specified therein as security for compliance of the Tenderer’s performance obligations in accordance with the Contract;

AND WHEREAS we have agreed to give the Tenderer a Guarantee;

THEREFORE WE HEREBY AFFIRM that we are Guarantors and responsible to you, on behalf of the Tenderer, up to a total of..... (*amount of the guarantee in words and figures*) and we undertake to pay you, upon your first written demand declaring the Tenderer to be in default under the Contract and without cavil or argument, any sum or sums within the limits of (*amount of guarantee*) as aforesaid, without you needing to prove or to show grounds or reasons for your demand or the sum specified therein.

This guarantee is valid until theday of.....20....

EITHER

SEALED with the)
COMMON SEAL)
of the said **INSTITUTION**)
)

thisday) _____
) INSTITUTION SEAL
 of20....)
 in the presence of :-)
)
 _____)
)
 and in the presence of:-)
)
 _____)

OR

SIGNED by the **DULY AUTHORISED REPRESENTATIVE(S)/ ATTORNEY(S)** of the **INSTITUTION**

 Name(s) and Designation of duly authorised representative(s)/ attorney(s) of the **Institution**.

 Signature(s) of the duly authorised person(s)

NOTES TO SUPPLIERS AND INSTITUTIONS

1. *Please note that no material additions, deletions or alterations regarding the contents of this Form shall be made to the Tender Security to be furnished by the Tenderer. If any are made, the Tender Security shall not be accepted and shall be rejected by KPLC. For the avoidance of doubt, such rejection will be treated as non-submission of the Tender Security where such Security is required in the tender.*

2. *It is the responsibility of the Tenderer to sensitize its issuing institution on the need to respond directly and expeditiously to queries from KPLC. The period for response shall not exceed three (3) days from the date of KPLC’s query. Should there be no conclusive response by the institution within this period, such Tenderer’s Tender Security shall be deemed as invalid and the bid rejected.*

3. *The issuing institution should address its response or communication regarding the Tender Security to KPLC at the following e-mail address – “guarantees@kplc.co.ke”*
4. *The Tender validity period is ninety (90) days as set out in the Invitation to Tender (at Section I of the Tender document) or as otherwise may be extended by KPLC. Therefore the Tender Security must at all times be valid for at least 30 days beyond the tender validity period.*

SECTION XI C - TENDER SECURITY – (LETTERS OF CREDIT)

The Mandatory Conditions to be included in the Letters are in two parts, A and B.

Part A

Form of Documentary credit - “Irrevocable Standby”

Applicable rules - “Must be UCP Latest Version” i.e. UCP 600 (2007 REVISION) ICC Publication No. 600.

Place of expiry - At the counters of the advising bank.

The SBLC should be available – “By Payment”

Drafts should be payable at - “SIGHT”

Documents required -

1. Beneficiary’s signed and dated statement demanding for payment under the letter of credit no..... (*Insert LC No.*) as.....(*Name of applicant*) (hereinafter called the “Tenderer”) indicating that the “Tenderer” has defaulted in the obligations of the Tenderer as stated by the Beneficiary.
2. The Original Letter of Credit and all amendments, if any.

Additional Conditions -

1. All charges levied by any bank that is party to this documentary credit are for the account of the applicant.
2. There should be no conditions requiring compliance with the specific regulations or a particular country’s Law and regulations.

Charges - All bank charges are for the account of the applicant.

*Confirmation instructions – (See notes below)

Part B

The proceeds of these Letters are payable to KPLC -

- a) if the Tenderer withdraws its Tender after the deadline for submitting Tenders but before the expiry of the period during which the Tenders must remain valid.
- b) if the Tenderer fails to enter into a written contract in accordance with the Tender Document
- c) if the successful Tenderer fails to furnish the performance security in accordance with the Tender Document.
- d) if the Tenderer fails to extend the validity of the tender security where KPLC has extended the tender validity period in accordance with the Tender Document.

NOTES TO TENDERERS AND BANKS.

1. *Please note that should the Tender Security (LC) omit any of the above conditions the LC shall not be accepted and shall be rejected by KPLC. For the avoidance of doubt, such rejection will be treated as non-submission of the LC where such LC is required in the Tender.*
2. *It is the responsibility of the Tenderer to sensitize its issuing bank on the need to respond directly and expeditiously to any queries from KPLC. The period for response shall not exceed three (3) days from the date of KPLC's query. Should there be no conclusive response by the Bank within this period, such Tenderer's Tender Security shall be deemed as invalid and the bid rejected.*
3. ***The issuing bank should address its response or communication regarding the bond to KPLC at the following e-mail address – “guarantees@kplc.co.ke”***
4. *The Tender validity period is ninety (90) days as set out in the Invitation to Tender (at Section I of the Tender document) or as otherwise may be extended by KPLC. Therefore the Tender Security must at all times be valid for at least 30 days beyond the tender validity period.*
5. *All Guarantees issued by foreign banks must be confirmed by a local bank in Kenya.*

SECTION XII A - MANUFACTURER’S AUTHORIZATION FORM

(To Be Submitted On Manufacturer’s Letterhead)

To:

The Kenya Power & Lighting Company Limited,
Stima Plaza, Kolobot Road, Parklands,
P.O Box 30099 – 00100,
Nairobi, Kenya.

WHEREAS WE(*name of the manufacturer*) who are established and reputable manufacturers of
(*name and description of the goods*) having factories at(*full address and physical location of factory(ies) where goods to be supplied are manufactured*) do hereby confirm that
(*name and address of Supplier*) is authorized by us to transact in the goods required against your Tender (*insert reference number and name of the Tender*) in respect of the above goods manufactured by us.

DATED THIS..... DAY OF.....20.....

Signature of duly authorised person for and on behalf of the Manufacturer.

Name and Designation of duly authorised person signing on behalf of the Manufacturer

NOTES TO TENDERERS AND MANUFACTURERS

Only a competent person in the service of the Manufacturer should sign this letter of authority.

SECTION XIIB - MANUFACTURER’S WARRANTY FORM

To Be Submitted On Manufacturer’s Letterhead)

To:

The Kenya Power & Lighting Company Limited,
Stima Plaza, Kolobot Road, Parklands,
P.O Box 30099 – 00100,
Nairobi, Kenya.

RE: MANUFACTURER’S WARRANTY FOR GOODS REQUIRED UNDER TENDER NO
..... TO BE SUPPLIED BY*(indicate your name*
or the supplier you have authorized)

WE HEREBY WARRANT THAT:

- a) The goods to be supplied under the contract are new, unused, of the most recent or current specification and incorporate all recent improvements in design and materials unless provided otherwise in the Tender.
- b) The goods in the Tenderer’s bid have no defect arising from manufacture, materials or workmanship or from any act or omission of the Tenderer that may develop under normal use of the goods under the conditions obtaining in Kenya.

The Warranty will remain valid for one (1) year after the goods, or any portion thereof as the case may be, have been delivered to the final destination indicated in the contract.

DATED THIS..... DAY OF.....20.....

Signature of duly authorised person for and on behalf of the Manufacturer.

Name and Capacity of duly authorised person signing on behalf of the Manufacturer

NOTES TO TENDERERS AND MANUFACTURERS

- 1. *Only a competent person in the service of the Manufacturer should sign this letter of authority.*
- 2. *Provide full contact details including physical address, e-mail, telephone numbers and the website on the Warranty.*

SECTION XIII - DECLARATION FORM

Date _____

To:

The Kenya Power & Lighting Company Limited,
P.O Box 30099 – 00100,
Stima Plaza, Kolobot Road, Parklands,
Nairobi,
KENYA.

Ladies and Gentlemen,

The Tenderer i.e. (full name and complete physical and postal address) _____

_____ declare the following: -

- a) That I/ We have not been debarred from participating in public procurement by anybody, institution or person.
- b) That I/ We have not been involved in and will not be involved in corrupt and fraudulent practices regarding public procurement anywhere.
- c) That I/We or any director of the firm or company is not a person within the meaning of paragraph 3.2 of ITT (Eligible Tenderers) of the Instruction to Tenderers.
- d) That I/ We are not insolvent, in receivership, bankrupt or in the process of being wound up and is not the subject of legal proceedings relating to the foregoing.
- e) That I/We do hereby confirm that all the information given in this tender is accurate, factual and true to the best of our knowledge.
- f) That I/ We are not associated with any other Tenderer participating in this tender

Yours sincerely,

Name of Tenderer

Signature of duly authorised person signing the Tender

Name and Designation of duly authorised person signing the Tender

Stamp or Seal of Tenderer

SECTION XIV – DRAFT LETTER OF NOTIFICATION OF AWARD

To: *(Name and full address of the Successful Tenderer)*.....

Date:.....

Dear Sirs/ Madams,

RE: NOTIFICATION OF AWARD OF TENDER NO.

We refer to your Tender dated..... and are pleased to inform you that following evaluation, your Tender has been accepted as follows: -

.....
.....

This notification does not constitute a contract. The formal Contract Agreement, which is enclosed herewith shall be entered into upon expiry of fourteen (14) days from the date hereof pursuant to the provisions of the Public Procurement and Asset Disposal Act, 2015 *(or as may be amended from time to time or replaced)*.

Kindly sign, and seal the Contract Agreement. Further, initial and stamp on all pages of the documents forming the Contract that are forwarded to you with this letter. Thereafter return the signed and sealed Contract together with the documents to us within fourteen (14) days of the date hereof for our further action.

We take this opportunity to remind you to again note and strictly comply with the provisions as regards the Tender Security, Signing of Contract and Performance Security as stated in the Instructions to Tenderers.

We look forward to a cordial and mutually beneficial business relationship.

Yours faithfully,

FOR: THE KENYA POWER & LIGHTING COMPANY LIMITED

GENERAL MANAGER, SUPPLY CHAIN

Enclosures

SECTION XV – DRAFT LETTER OF NOTIFICATION OF REGRET**To:** *(Name and full address of the Unsuccessful Tenderer)*.....**Date:**

Dear Sirs/ Madams,

RE: NOTIFICATION OF REGRET IN RESPECT OF TENDER NO.

We refer to your Tender dated..... and regret to inform you that following evaluation, your Tender is unsuccessful. It is therefore not accepted. The brief reasons are as follows:-

1.
2.
3. etc...

The successful bidder was _____.

However, this notification does not reduce the validity period of your Tender Security. In this regard, we request you to relook at the provisions regarding the Tender Security, Signing of Contract and Performance Security as stated in the Instructions to Tenderers.

You may collect the tender security from our *Legal Department (Guarantees Section), on the 2nd Floor, Stima Plaza, Kolobot Road, Parklands, Nairobi* only after expiry of twenty five (25) days from the date hereof on Mondays and Wednesdays ONLY between 9.00 a.m. to 12.30 pm and 2.00p.m to 4.00p.m.

It is expected that by that time KPLC and the successful bidder will have entered into a contract pursuant to the Public Procurement and Asset Disposal Act, 2015 (*or as may be amended from time to time or replaced*). When collecting the Security, you will be required to produce the original or certified copy of this letter.

We thank you for the interest shown in participating in this tender and wish you well in all your future endeavours.

Yours faithfully,

FOR: THE KENYA POWER & LIGHTING COMPANY LIMITED**GENERAL MANAGER, SUPPLY CHAIN**

SECTION XVI - CONTRACT AGREEMENT FORM

THIS AGREEMENT made this.....day of.....20.... **BETWEEN THE KENYA POWER & LIGHTING COMPANY LIMITED**, a limited liability company duly incorporated under the Companies Act, Chapter 486 of the Laws of Kenya, with its registered office situated at Stima Plaza, Kolobot Road, Parklands, Nairobi in the Republic of Kenya and of Post Office Box Number 30099-00100, Nairobi in the Republic aforesaid (*hereinafter referred to as the "KPLC"*) of the one part,

AND

..... (*Supplier's full name and principal place of business*) a duly registered entity according to the laws of..... (*state country*) and of Post Office Box Number/Physical Address(*full address of Supplier*) in the Republic aforesaid, (*hereinafter referred to as the "Supplier"*) of the other part;

WHEREAS KPLC invited tenders for certain goods, that is to say for(*KPLC Supply Chain – Procurement Department insert description of goods*) under Tender Number..... (*KPLC Supply Chain – Procurement Department insert tender number*)

AND WHEREAS KPLC has accepted the Tender by the Supplier for the goods in the sum of(*KPLC Supply Chain – Procurement Department specify the total amount in words which should include any payable taxes, duties and insurance where applicable e.g. Value Added Tax*) (*hereinafter called "the Contract Price"*).

NOW THIS AGREEMENT WITNESSETH AS FOLLOWS: -

1. In this Agreement words and expressions shall have the same meanings as are respectively assigned to them in the Conditions of Contract and the Tender Document.
2. Unless the context or express provision otherwise requires: -
 - a) reference to "this Agreement" includes its recitals, any schedules and documents mentioned hereunder and any reference to this Agreement or to any other document includes a reference to the other document as varied supplemented and or replaced in any manner from time to time.
 - b) any reference to any Act shall include any statutory extension, amendment, modification, re-amendment or replacement of such Act and any rule, regulation or order made there-under.
 - c) words importing the masculine gender only, include the feminine gender or (as the case may be) the neutral gender.

TENDER FOR SUPPLY OF MOTOR VEHICLES, MOTOR CYCLES & PLANT- AUGUST 2017

- d) words importing the singular number only include the plural number and vice-versa and where there are two or more persons included in the expression the “*Supplier*” the covenants, agreements obligations expressed to be made or performed by the Supplier shall be deemed to be made or performed by such persons jointly and severally.
 - e) where there are two or more persons included in the expression the “*Supplier*” any act default or omission by the Supplier shall be deemed to be an act default or omission by any one or more of such persons.
3. In consideration of the payment to be made by KPLC to the Supplier as hereinafter mentioned, the Supplier hereby covenants with KPLC to supply the goods and remedy any defects thereon in conformity in all respects with the provisions of the Contract.
 4. KPLC hereby covenants to pay the Supplier in consideration of the proper supply of the goods and the remedying of defects therein, the Contract Price or such other sum as may become payable under the provisions of the Contract at the times and in the manner prescribed by the Contract.
 5. The following documents shall constitute the Contract between KPLC and the Supplier and each shall be read and construed as an integral part of the Contract: -
 - a) this Contract Agreement
 - b) the Special Conditions of Contract as per the Tender Document
 - c) the General Conditions of Contract as per the Tender Document
 - d) the Price Schedules submitted by the Supplier and agreed upon with KPLC
 - e) the Technical Specifications as per KPLC’s Tender Document
 - f) the Schedule of Requirements
 - g) KPLC’s Notification of Award dated.....
 - h) the Tender Form signed by the Supplier
 - i) the Declaration Form signed by the Supplier/ successful Tenderer
 - j) the Warranty
 - k) the Delivery Schedule
 6. In the event of any ambiguity or conflict between the contract documents listed above, the order of precedence shall be the order in which the contract documents are listed in 5 above except where otherwise mutually agreed in writing.
 7. The Commencement Date shall be the working day immediately following the fulfillment of all the following: -
 - a) Execution of this Contract Agreement by KPLC and the Supplier.

- b) Issuance of the Performance Bond by the Supplier and confirmation of its authenticity by KPLC.
- c) Issuance of the Official Order by KPLC to the Supplier.
- d) Where applicable, Opening of the Letter of Credit by KPLC.

8. The period of contract validity shall begin from the Commencement date and end on -
- a) sixty (60) days after the last date of the agreed delivery schedule, or,
 - b) where a Letter of Credit is adopted as a method of payment, sixty (60) days after the expiry date of the Letter of Credit or the expiry date of the last of any such opened Letter of Credit whichever is later.

Provided that the expiry period of the Warranty shall be as prescribed and further provided that the Warranty shall survive the expiry of the contract.

9. It shall be the responsibility of the Supplier to ensure that its Performance Security is valid at all times during the period of contract validity and further is in the full amount as contracted.
10. Any amendment, change, addition, deletion or variation howsoever to this Contract shall only be valid and effective where expressed in writing and signed by both parties.
11. No failure or delay to exercise any power, right or remedy by KPLC shall operate as a waiver of that right, power or remedy and no single or partial exercise of any other right, power or remedy shall operate as a complete waiver of that other right, power or remedy.
12. Notwithstanding proper completion of delivery or parts thereof, all the provisions of this Contract shall continue in full force and effect to the extent that any of them remain to be implemented or performed unless otherwise expressly agreed upon by both parties.
13. Any notice required to be given in writing to any Party herein shall be deemed to have been sufficiently served, if where delivered personally, one day after such delivery; notices by electronic mail and facsimile shall be deemed to be served one day after the date of such transmission and delivery respectively (*and proof of service shall be by way of confirmation report of such transmission and or delivery*), notices sent by post shall be deemed served seven (7) days after posting by registered post (*and proof of posting shall be proof of service*), notices sent by courier shall be deemed served two (2) days after such receipt by the courier service for Local (Kenyan) Suppliers and five (5) days for Foreign Suppliers.
14. For the purposes of Notices, the address of KPLC shall be Company Secretary, The Kenya Power & Lighting Company Limited, 7th Floor, Stima Plaza, Kolobot Road, Post Office Box Number 30099-00100, Nairobi, Kenya, Facsimile + 254-20-3514485. The address for the

Supplier shall be the Supplier's address as stated by it in the Confidential Business Questionnaire provided in the Tender Document.

IN WITNESS whereof the parties hereto have caused this Agreement to be executed in accordance with the laws of Kenya the day and year first above written.

SIGNED FOR and on **BEHALF**
of **KPLC**

MANAGING DIRECTOR & CEO

and in the presence of:-

COMPANY SECRETARY

SEALED with the **COMMON SEAL**
of the **SUPPLIER**
in the presence of:-

DIRECTOR

Affix Supplier's Seal here

DIRECTOR'S FULL NAMES

and in the presence of:-

DIRECTOR/ COMPANY SECRETARY

DIRECTOR/ COMPANY SECRETARY'S FULL NAMES

*OR

SIGNED BY and on **BEHALF**
of the **SUPPLIER**

SIGNATURE OF THE SUPPLIER

FULL NAMES OF THE SUPPLIER

***NOTES TO THE SUPPLIER**

1. *Please note that the alternative is applicable IF AND ONLY IF the Supplier is not a registered company but has tendered, and, is trading as a sole proprietor or a partnership as provided in the Confidential Business Questionnaire or is registered as a business name.*
2. *In all other cases, the Supplier is required to execute the contract as first provided.*

DRAWN BY: -

Awuor Owiti,

Advocate,

C/o The Kenya Power & Lighting Company Limited,

7th Floor, Stima Plaza,

Kolobot Road, Parklands,

Post Office Box Number 30099-00100,

NAIROBI, KENYA,

Telephones: + 254-20-3201000/ 731

Facsimile: + 254-20-3514485

SECTION XVII A - PERFORMANCE SECURITY FORM (BANK GUARANTEE)

(To Be Submitted On Bank’s Letterhead)

Date:

To:

The Kenya Power & Lighting Company Limited,
Stima Plaza,
Kolobot Road, Parklands,
P.O Box 30099 – 00100,
Nairobi, Kenya.

WHEREAS.....(hereinafter called “the Supplier”) has undertaken, in pursuance of your Tender Number.....(*reference number of the Tender*) and its Tender dated(*insert Supplier’s date of Tender taken from the Tender Form*) to supply(*description of the goods*) (hereinafter called “the Contract);

AND WHEREAS it has been stipulated by you in the said Contract that the Supplier shall furnish you with a bank guarantee by an acceptable bank for the sum specified therein as security for compliance of the Supplier’s performance obligations in accordance with the Contract;

AND WHEREAS we have agreed to give the Supplier a guarantee;

THEREFORE WE HEREBY AFFIRM that we are Guarantors and responsible to you, on behalf of the Supplier, up to a total sum of..... (*amount of the guarantee in words and figures*) and we undertake to pay you, upon your first written demand declaring the Supplier to be in default under the Contract and without cavil or argument, any sum or sums within the limits of
(*amount of guarantee*) as aforesaid, without you needing to prove or to show grounds or reasons for your demand or the sum specified therein.

This guarantee is valid until theday of.....20....

EITHER

SEALED with the)
COMMON SEAL)
of the said **BANK**)
)

thisday)

BANK SEAL

_____)
 of20....)
 in the presence of :-)
 _____)
 _____)
 and in the presence of:-)
 _____)
 _____)

OR

SIGNED by the **DULY AUTHORISED**
REPRESENTATIVE(S)/ ATTORNEY(S) of
 the **BANK**

 Name(s) and Designation of duly authorised representative(s)/ attorney(s) of the Bank

 Signature(s) of the duly authorised person(s)

NOTES TO SUPPLIERS AND BANKS

1. *Please note that no material additions, deletions or alterations regarding the contents of this Form shall be made to the Performance Security Bond (the Bond) to be furnished by the successful Tenderer/ Supplier. If any are made, the Bond may not be accepted and shall be rejected by KPLC. For the avoidance of doubt, such rejection will be treated as non-submission of the Bond where such Bond is required in the tender and Contract.*

3. *KPLC shall seek authentication of the Performance Security from the issuing bank. It is the responsibility of the Supplier to sensitize its issuing bank on the need to respond directly and expeditiously to queries from KPLC. The period for response shall not exceed three (3) days from the date of KPLC’s query. Should there be no conclusive response by the Bank within this period, such Supplier’s Performance Security may be deemed as invalid and the Contract nullified.*

3. *The issuing Bank should address its response or communication regarding the bond to KPLC at the following e-mail address – “guarantees@kplc.co.ke”*

SECTION XVII B - PERFORMANCE SECURITY (LC)

Mandatory Conditions that should appear on the Performance Security (LC).

Form of Documentary credit - “Irrevocable Standby”

Applicable rules - “Must be UCP Latest Version” i.e. UCP 600 (2007 REVISION) ICC Publication No. 600.

Place of expiry - At the counters of the advising bank.

The SBLC should be available – “By Payment”

Drafts should be payable at - “SIGHT”

Documents required -

1. Beneficiary’s signed and dated statement demanding for payment under the letter of credit no..... *(Insert LC No.)* as.....*(Name of Applicant)* (hereinafter called the “Supplier”) indicating that the “Supplier” has defaulted in the performance and adherence to and performance of the contract between the Beneficiary and the Supplier.
2. The Original Letter of Credit and all amendments, if any.

Additional Conditions -

1. All charges levied by any bank that is party to this documentary credit are for the account of the Applicant.
2. (Include) that there should be no conditions requiring compliance with the specific regulations or a particular country’s laws and regulations.

Charges - All bank charges are for the account of the Applicant.

Confirmation instructions – (See notes below)

NOTES TO SUPPLIERS AND BANKS

1. *Please note that should the Performance Security (LC) omit any of the above conditions the LC shall not be accepted and shall be rejected by KPLC. For the avoidance of doubt, such rejection will be treated as non-submission of the LC where such LC is required in the tender and Contract.*
2. *KPLC may seek authentication of the Performance Security (LC) from the issuing bank. It is the responsibility of the Supplier to sensitize its issuing bank on the need to respond directly and expeditiously to queries from KPLC. The period for response shall not exceed three (3) days from the date of KPLC’s query. Should there be no conclusive response by the Bank*

TENDER FOR SUPPLY OF MOTOR VEHICLES, MOTOR CYCLES & PLANT- AUGUST 2017

within this period, such Supplier's Performance Security (LC) may be deemed as invalid and the Contract nullified..

- 4. The issuing bank should address its response or communication regarding the bond to KPLC at the following e-mail address – “guarantees@kplc.co.ke”*
- 4. All Guarantees issued by foreign banks must be confirmed by a local bank in Kenya.*

SECTION XVIII – SUBCONTRACTORS**(INFORMATION TO BE PROVIDED BY THE TENDERER)**

As per the requirements of Clause 7.23 of General Conditions of Contract, following is a list of subcontractors and the portions of the Work to be subcontracted:

No.	Subcontractor	Address	Brief Description of the Works to be Subcontracted	% works subcontracted

SECTION XIX - PREVIOUS EXPERIENCE WITH SIMILAR WORK**(INFORMATION TO BE PROVIDED BY THE TENDERER)**

As required by Section 3.13.3(d) of the Instructions To Tenderers, following is a list of work that the Tenderer has previously performed which is similar to that described in the Request for Proposal:

No.	Description	Customer Name & Contacts	Date of Supply

SECTION XX - SUPPLIER EVALUATION FORM

(This form is for information only and not to be filled in by any bidder. It is for official use by KPLC to evaluate performance of Suppliers during the contract period)

Name of Firm.....Date.....

Category of Product/Service (e.g. Motor Vehicles / Cycles and Plant)

Period of evaluation.....

1. COST OF SERVICE/PRODUCT	Rating guidelines				Supplier Score	Procurement Score	User Score	Comments	Totals
	Did the vendor assist in or advice on ways of reducing the costs?	YES:4	PARTIALLY:2	NO: 0					10
	How closely did your final costs correspond to your expectation at the beginning of the project/tender?	YES:2	PARTIALLY:1	NO: 0					10.00%
	Did the company stick to the agreed transaction/contract rates?	YES:4	PARTIALLY:2	NO: 0					
									Totals
2.ON TIME DELIVERY OF PRODUCT OR SERVICE									
	Did the vendor perform work in compliance with contract terms and agreements?	YES:6	PARTIALLY:3	NO: 0					10
	Was the vendor prompt and effective in correction of situations and conditions?	YES:2	PARTIALLY:1	NO: 0					10.00%
	Are you able to track service level agreements and determine duration of incidents from the vendor?	YES:2	PARTIALLY:1	NO: 0					
									Totals
3. FLEXIBILITY TO RESPOND TO UNEXPECTED DEMAND OF SERVICE									
	Was the vendor willing to change their product/service on special needs?	YES:6	PARTIALLY:3	NO: 0					6
									6.00%
4. QUALITY									Totals
	When performing their duties, was there - rework or returns caused by non-conformance to quality?	NO:6	PARTIALLY:3	YES: 0					14
	Was the quality of service delivered equal to KPLC minimum requirements?	YES:8	PARTIALLY:4	NO:0					14.00%
5.RESPONSIVENESS									Totals
	Was the vendor well responsive to information requests, issues, or problems that arose in the course of service?	YES:2	PARTIALLY:1	NO: 0					14
	Was the vendor open to feedback on low quality of service levels and willing to act on this?	YES:6	PARTIALLY:3	NO: 0					14.00%
	Is it easy to reach staff members of suppliers in case of a request or query? (are communication channels clear?)	YES:6	PARTIALLY:3	NO: 0					
									Totals
6. CUSTOMER SUPPORT									
	Did the vendor offer effective customer support?	YES:10	PARTIALLY:4	NO: 0					18
	In case of reported problems/issues, were there follow ups by the vendor to ensure the problem is fully resolved during support?	YES:8	PARTIALLY:4	NO: 0					18.00%
7. COMMUNICATION SKILLS									Totals
	Are you satisfied with the attitude, courtesy, and professionalism of this vendor's staff? Written or spoken?	YES:2	PARTIALLY:1	NO: 0					6

TENDER FOR SUPPLY OF MOTOR VEHICLES, MOTOR CYCLES & PLANT- AUGUST 2017

	Are the vendor's staff well equipped and skilled in handling requests / issues? Are you rotated too much among staff on an issue?	YES:4	PARTIALLY:2	NO: 0					6.00%
8. DOCUMENTATION AND ACCOUNTING	Rating guidelines								Totals
	Are you satisfied with how the Vendor presents documentation (invoices & licenses etc.) when required to do so, to necessitate finalization of contract renewals and payments?	YES:6	PARTIALLY:3	NO: 0					10
	Was problem documentation (incident reports) presented promptly by the vendor and was it complete?	YES:4	PARTIALLY:2	NO: 0					10.00%
9. VALUE ADD	Rating guidelines								Totals
	Did the vendor go over and above in optimizing service delivery process for effective services delivery?	YES:6	PARTIALLY:3	NO: 0					12
	Did the vendor go over and above and offer training or knowledge to assist with better systems support?	YES:6	PARTIALLY:3	NO: 0					12.00%
									Totals Score:
Totals									100.0
Maximum Score							100.0		100.00%
VENDOR'S TOTAL SCORE									
VENDOR'S PERCENTAGE SCORE									
ISSUES FOR FOLLOW UP -									
Evaluation Done by: Name Department Date									
Checked/Validated by									

Score in Percentage %

PERFORMANCE LEVEL DEFINATION;

- ≥75% - KP1 GREEN
- 50% - KP2 AMBER
- 25% - KP3 YELLOW
- ≥25% - KP4 RED

RATING: 75% - V Good, 50% - Good, 25% - Fair, Below 25% - Poor

RECOMMENDATION

		Status	Tick as appropriate
1	Grant supplier preferred status	KP1	
2	Work with supplier or develop and improve supplier	KP2 & KP3	
3	Abandon / switch suppliers	KP4	

Name:.....Sign:.....Date:.....

Name:.....Sign:.....Date:.....

Name:.....Sign:.....Date:.....

SECTION XXI - THE TECHNICAL SPECIFICATIONS

Technical specifications describe the basic requirements for goods. In addition to the information and documentation in the Tender Document regarding the technical aspects of this tender, all Tenderers shall comply with the following -

PART A - GENERAL REQUIREMENTS

The specifications given below are only minimal. The bidder should give detailed specifications of the Motor Vehicles & Plant offered (**In the Detailed Technical Specifications attached**). The technical features specified are only indicative and bidders can offer alternative Motor Vehicles provided evidence is given to prove that the alternatives offered are equivalent or superior to the ones specified by the purchaser.

Standard production Motor Vehicles & M/Cycles of latest design, robust construction and current production for short and long distance transportation of goods and materials.

1. Technical documentation shall be in English language. The specific items on offer shall be marked clearly for the goods they intend to supply. The type reference or model number(s) of the item(s) on offer must be clearly indicated in the bid.
2. The Tenderer shall submit the Schedule of Guaranteed Technical Particulars (GTP) completed and signed by the Manufacturer. In submitting the GTP, cross-references should be made to the documents submitted.
3. Deviations from the tender specifications, if any, shall be explained in detail in writing, with supporting data including calculation sheets, detailed drawings and certified test reports and submitted together with the Tender. In submitting the deviations, cross-references should be made to the documents submitted. KPLC reserves the right to reject the goods if such deviations shall be found critical to the use and operation of the goods.
4. Detailed contact information including title, e-mail, facsimile, telephone or any other form of acceptable communication of the testing and standards body used shall be provided.
 1. Where Type Test Certificates and their Reports and or Test Certificates and their Reports are translated into English, all pages of the translations must be signed and stamped by the testing authority.
5. A Copy of the manufacturer's valid quality management system certification i.e. ISO 9001 shall be submitted for evaluation. For locally manufactured goods, valid KEBS Diamond Mark of Quality Certificate or KEBS Standardization Mark Certificate will also be accepted.

6. In all cases where the level of galvanizing and painting is not specifically stated in the detailed Technical Specifications, the general requirement shall be for a uniform coating of thickness not less than 80 microns.
7. Suppliers are required to provide information on proper representative(s) and or workshop for back-up service and or repair and maintenance including their names, telephone, facsimile, e-mail, physical and postal addresses, along with their offers

8. **PAINTING AND PAINT WORK**

Unless where specified all the Motor Vehicles will be painted in the Kenya Power & Lighting Company colours. Body panels should be thoroughly cleaned and an etching solution used to remove rust before painting. Both external and internal paint should be preceded by prime coat and undercoat and at least two coats of high quality gloss finish to the Kenya Power and Lighting Company colours. KPLC Blue paint can be viewed at Transport Ruaraka so that there is no tone mismatch between the new Motor Vehicles and the existing fleet.

9. **VEHICLE ACCESSORIES**

All Motor Vehicles & Plant will be supplied complete with accessories which include and is not limited to:-

- (a) Service manuals.
- (b) Necessary tool kits as recommended by the manufacturer.

10. **AFTER SALES SERVICE & SUPPLY OF SPARE PARTS**

Tenderers must offer items with service and spares parts back-up. Documentary evidence and locations of such back- up must be given. Where a tenderer offers items without such back-up in the country, he must give documentary evidence and assurance that he will establish adequate back-up for items supplied. Bidders should give: -

- a) Name and Address of its local agent representative in Kenya.
- b) Name(s) and Address (es) of dealer(s) who stock spare parts in Kenya.
- c) Name(s) and Address (es) of dealer(s) in Kenya where back up service can be obtained indicating the qualifications of personnel(s) involved.

11. **OPTIONAL EXTRAS**

Bidders shall submit details of fittings, which shall be supplied as optional extras, and cost of such extras to be quoted for separately.

12. **TRAINING**

The bidder should provide adequate training for a reasonable number of mechanics/operators and their supervisors.

The training should cover the following: -

- (i) Trouble shooting indicators and diagnosis of their possible causes and remedy.
 - (ii) Engine Tuning, Unit Overhauls, Parts replacement, adjustments and routine maintenance.
 - (iii) Repair and maintenance techniques of other mechanical systems including the transmission, braking and the suspension systems.
1. Electrical system - Repair, replacement, adjustment and maintenance of electrical components and parts.

13. **MANUALS**

The following manuals in English should be supplied.

- (a) Maintenance and service manual with diagrams.
- (b) Drivers Operations manual.
- (c) Five Spare parts catalogues with detailed diagram.
- (d) Five Shop/repair manuals per model

14. **SAMPLE**

The Transport Manager, will avail sample Motor Vehicles for viewing if required.

15. **INSPECTION AND TESTS**

Purchaser's representative shall carry out Benchmark inspection and tests for quantity and quality at Supplier's premises before delivery to Ruaraka Transport Workshop.

16. **POOR WORKMANSHIP**

In the event of poor workmanship or non-compliance with the specifications the Kenya Power & Lighting Company reserves the right to accept or reject the Motor Vehicles, M/Cycles & Plant. The Contractor will make good any deficiencies, shortfalls or poor workmanship at his cost.

PART B – DETAILED TECHNICAL SPECIFICATIONS (DTS)

The Detailed Technical Specifications are as attached on the next page
(Specifications for Motor Vehicle, Motor Cycles & Plant)

HEAVY DUTY, UTILITY PASSENGER VEHICLE, 4x4, L.W.B., 2400cc-3000cc, DIESEL.
QUANTITY: 2

Specification No. KPLC-TPT-01-17-18

Description: Heavy duty, utility passenger vehicle, 4x4, L.W.B., 2400cc-3000cc, Diesel.

Tenderers's name.....

	KPLC Requirements	Tenderer's Offer
1. GENERAL.		
a) Make	-	
b) Model	-	
c) Country of origin	-	
d) Manufacturer's Authorization Supplied	Yes (Mandatory)	
e) Manufacturer's Literature & Brochures Supplied.	Yes (Mandatory)	
f) Technical Specification Sheet fully completed and submitted.	Yes (Mandatory)	
g) A standard production, 4x4, Diesel utility vehicle station wagon of latest design in the class, robust construction in current production and marketed in Kenya.	Yes (Mandatory)	
h) Supplied new.	Yes (Mandatory)	
i) Designed to light utility specifications, capable of operating in tropical conditions in extremes of mud and dust.	Yes (Mandatory)	
j) Most suitable for operating both "on and off" road conditions.	Yes (Mandatory)	
k) Most suitable for personnel transportation.	Yes (Mandatory)	
2. DIMENSIONS AND WEIGHTS.		
a) Overall length min.	5000mm Yes (Mandatory)	
b) Overall width, min.	2200mm Yes (Mandatory)	
c) Overall height approx.	Yes, 1850mm	
d) Wheelbase min.	2700mm Yes (Mandatory)	
e) Max. G.V.W. approx.	Yes, 3000kg	
f) Kerb weight. Max.	Yes, 1800kg	
g) Ground clearance, min.	200mm Yes (Mandatory)	
h) Minimum turning radius, approx.	7.0m	
i) Max. gradient, min	0.6 Yes	
j) Wading depth, min.	400mm Yes	
3. ENGINE.		
a) Make	-	
b) Model	-	

c) Country of origin	-	
d) Engine performance curves supplied	Yes	
e) Engine type, diesel, 4 stroke, water cooled	Yes (Mandatory)	
f) Piston displacement, within the range.	2400-3000cc Yes (Mandatory)	
g) Number of cylinders, min.	4 No.	
h) Maximum power output (Kw/rpm), approx.	70kw/4000rpm Yes (Mandatory)	
i) Maximum torque developed (Nm/rpm), approx.	400Nm/2000rpm Yes (Mandatory)	
j) Engine aspiration, natural/turbocharger	Specify	
k) Air filter, disposable/oil bath	Specify	
l) Average fuel consumption (on full load)		
Urban driving	Specify Kms/lit	
Steady 50km/hr	Specify Kms/lit	
Steady 80km/hr	Specify Kms/lit	
m) Fuel tank capacity, min.	90 Liters	
4. CLUTCH AND TRANSMISSION		
a) Clutch, dry single plate, diaphragm type	Specify	
b) Hydraulic, clutch actuation	Yes	
c) All synchromesh gearbox, with 2 speed reduction transfer gearbox	Yes	
d) Transmission speeds,	5 speed Yes (Mandatory)	
e) Permanent 4WD or with selector from 2WD to 4WD	Specify	
f) Differential lock provided	Specify	
g) Freewheeling hubs fitted	Specify	
5. ELECTRICALS		
a) System voltage, negative earth, with alternator charging	Yes (Mandatory)	
b) Battery capacity.	1x12V, 70AH	
c) Standard instrument and gauges, warning lights for charging circuit, oil pressure, coolant temperature etc.	Yes (Mandatory)	
6. BRAKES AND TYRES		
a) Assisted hydraulic, dual brake system	Yes, Yes	
b) Drum or disc brake	Specify front	
	Specify rear	
c) Mechanical parking brake, to act on transmission or rear wheels	Yes Specify	
d) Tyre locally manufactured	Yes	
e) Optimum tyre size	Specify size	

f) Tubed or Tubeless	Specify	
7. SUSPENSION AND STEERING		
a) Independent heavy duty front and rear suspension		
b) Heavy duty leaf or coil springs with telescopic dampers	Specify Front:	
	Rear:	
a) Power assisted steering system.	Yes (Mandatory)	
b) Right hand drive steering	Yes (Mandatory)	
8. STATION WAGON		
c) 4 No. side doors and rear side-swing door station wagon	Yes (Mandatory)	
d) To seat at least 7 adults including driver comfortably.	Yes (Mandatory)	
e) Seating arrangements: 2 in front, 3 in middle, & 3-4 at the rear (front facing or facing each other)	Yes (Mandatory)	
f) To be fitted with adequate winding/sliding windows for good ventilation and wide view	Yes	
9. BODY AND FINISH.		
a) All exterior body panels made non- corrosive, and all external steel fitting to be galvanized or painted	Yes	
b) Anti-rust compound applied to under body for seaside operation	Yes	
c) Body finish, high gloss as specified by the user.	Yes (Mandatory)	
d) Suitable bumper bar for fitting Electric winch.	Yes (Mandatory)	
e) Fitted with reclining and adjustable driver and passenger seats	Yes	
f) Upholstery reinforced PVC.	Yes (Mandatory)	
10.ELECTRICAL SYSTEM AND INSTRUMENTS.		
a) System voltage, negative earth, with alternator charging	12V, Yes, Yes	
b) Battery capacity	1x12V, 70Ah	
c) Full lighting to conform to Cap 403, subs 23-Kenya Traffic Act	Yes	
d) Standard instruments and gauges (or warning lights) for charging circuit, oil pressure, coolant temperature etc.	Yes	
11.EQUIPMENT.		
a) Heavy duty front fender fitted	Yes	
b) Rear view mirrors supplied 2 No. External, 1 No. Internal	Yes	

c) FM, MW, SW radio cassette fitted.	Yes	
d) Spare wheel and external carrier supplied.	Yes	
e) Manufacturer's standard tools, supplied.	Specify	
f) Hydraulic (telescopic) jack, wheel brace & manufacturer's standard tools	Yes	
g) Vehicle to be fitted with electronic speed governor.	Yes (Mandatory)	
h) Sun visors supplied.	Yes (Mandatory)	
i) Heavy duty hooks at rear and front	Yes (Mandatory)	
j) Safety belts provided for all seats belts conforming to KEBS 06-664: 1985 Standard	Yes (Mandatory)	
k) Anti-theft alarm fitted.	Yes (Mandatory)	
l) Metallic Hazard Triangles, standard First Aid KS-2094-2007 and 1Kg fire extinguisher.	Yes (Mandatory)	
m) Supply addition Loose Floor rubber mats	Yes	
n) Air conditioner	Yes	
o) Air bags	Yes	
12. WARRANTY & FREE SERVICE.		
a) Specimen of vehicle warranty to be submitted when tendering	Yes	
b) Each vehicle supplied should carry a	Yes	
c) statement of warranty	Yes (Mandatory)	
Vehicle warranty min., 12 Months or	Specify months	
40,000Km, whichever comes first	Specify Kms (Mandatory)	
d) Vehicle Free Service on Labour & Parts	Parts (Kms)	
	Labour (Kms)	
13. MANUALS.		
a) All literature in the English language	Yes (Mandatory)	
b) Repair manuals, supplied	Yes (Mandatory)	
c) Parts catalogue/microfiche/CD, supplied	Yes (Mandatory)	
d) Drivers handbook supplied	Yes	
e) Service schedule supplied	Yes	
14. OTHER REQUIREMENTS.		
a) Manufacturers' authorization supplied when tendering.	Yes (Mandatory)	
b) Evidence (in form of purchase documents) of minimum 10 units sold and serviced in Kenya.	Yes (mandatory)	
c) Vehicle to be registered by Registrar of Motor Vehicles	Yes (Mandatory)	
d) Vehicle to be inspected by the KPLC Engineer prior to delivery	Yes (Mandatory)	
e) Franchise Holders and dealers who own fully fledged workshops with adequate equipment and	Yes (Mandatory)	

facilities.		
f) Body construction and all fitments to conform to Kenya Traffic Act CAP 403.	Yes (Mandatory)	
g) Car identity on all Glasses and Lights	Yes	
h) Indicate name and physical addresses of all Dealers / Agents where Genuine Spares and back-up service can be obtained in at least five (5) major Kenya Power depots (Nairobi, Mombasa, Kisumu, Nyeri, Nakuru and Eldoret).	Attach list – Yes (Mandatory)	

LIGHT TRUCK, 4X2, 4.0-5.0 TON, 3800-4500cc, DIESEL.Quantity: **15**Specification No. **KPLC-TPT-02-17-18**

Description: Light truck, 4x2, 4.0-5.0 Ton, Low sided body, Constructed suitably for fitting street lighting equipment.

Tenderers's name:.....

	KPLC requirements.	Tenderer's Offer
1. GENERAL:		
a) Make:	-	
b) Model:	-	
c) Country of origin:	-	
d) Manufacturer's Authorization Supplied	Yes (mandatory)	
e) Manufacturer's Literature & Brochures Supplied.	Yes (mandatory)	
f) Technical Specification Sheet fully completed and submitted.	Yes (mandatory)	
g) A standard production, 4x2, 4.0-5.0-ton payload truck of latest design in robust construction in current production marketed in Kenya.	Yes (mandatory)	
h) Supplied new.	Yes (mandatory)	
i) Designed to heavy duty export specs, capable of operating in tropical conditions over paved and unpaved roads	Yes	
j) Control Forward/Normal	Specify	
k) Suitable for electric Poles transportation as per the supplied Drawing.	Yes (mandatory)	
2. DIMENSIONS AND WEIGHTS		
a) Overall length min.	6,400 mm Yes (mandatory)	
b) Overall width min.	1,900 mm Yes (mandatory)	
c) Overall Height, min.	2,100 mm	
d) Wheel base min	3,400 mm Yes (mandatory)	
e) Cab to rear axle, min.	4,900mm Yes (mandatory)	
f) Kerb (Tare)weight, min.	2,300 Kg Yes (mandatory)	
g) Max. G.V.W, within range	7000-7500 Kg Yes (mandatory)	
h) Payload, within the range.	4,000 – 5,000 Kg	

	Yes (mandatory)	
i) Ground Clearance, min.	200 mm Yes (mandatory)	
3. ENGINE		
a) Make	-	
b) Model	-	
c) Country of origin	-	
d) Engine performance curves supplied	Yes (mandatory)	
e) Diesel Engine, water cooled, 4 stroke	Yes (mandatory)	
f) Mode of aspiration (Natural/Turbo)	Specify	
g) Piston displacement within range.	3,800 – 4,500 cc Yes (mandatory)	
h) Number of cylinders, 4/6	Specify	
i) Maximum power output /rpm min.	85Kw/3500rpm Yes (mandatory)	
j) Maximum torque developed/rpm), min	270Nm/1800rpm Yes (mandatory)	
k) Air cleaner type, disposable/oil bath	Specify	
l) Oil and fuel filter type	Disposable	
m) Average fuel consumption (on full load)	5 Kms/Lit.	
n) Fuel tank capacity, approx.	100 Lts	
4. CLUTCH AND TRANSMISSION		
a) Clutch, dry single plate,	Yes	
b) Clutch system actuation, Hydraulic	Yes	
c) Gearbox, synchromesh	Yes	
d) Number of speeds, min.	5F, 1R (mandatory)	
e) Drive configuration	4x2	
5. BRAKES TYRES AND SUSPENSION		
a) Brakes, hydraulic-pneumatic assisted	Yes	
b) Mechanical parking brake, to act on transmission-rear wheels	Yes	
c) Rear tyres	Dual	
d) Tyres size 215/65R16 locally manufactured	Yes	
e) Optimum tyre size	Specify	
f) Suspension, front and rear heavy duty leaf springs with telescopic shock absorbers at front	Yes	
6. STEERING, CONTROL AND CAB		
a) Right Hand Drive steering	Yes	
b) Power assisted Steering type.	Yes (mandatory)	
c) All steel, spacious front cab to seat 3-passengers comfortably.	Yes	

d) Adjustable driver's seat.	Yes	
e) Seat belts.	Yes	
7. BODY CONSTRUCTION AND FITTINGS		
a) Low sided body with drop side doors suitable for fitting hydraulic street lighting equipment.	Yes (mandatory)	
b) Body cross bearers of pre-stressed channel sections, 100x50x4.5mm equidistantly spaced at a maximum of 500mm apart.	Yes	
c) Suitable size well-seasoned timber runners, with inverted steel section at top, between body frame and chassis.	Yes	
d) Body secured to chassis by U- bolts, diameter 16mm, held in position on wooden V-blocks.	Yes	
e) Body floor fabricated from 3.2mm thick mild steel plate (full width) reinforced at equal distances with box/channel sections.	Yes	
f) Steel platform body, made from mild steel chequered plate of thickness 3.2mm.	Yes (Mandatory)	
g) Suitable size toolbox to be fitted on to the cargo carrier.	Yes	
h) Body cargo carrier front reinforced suitably to carry heavy loads as per the given drawing.	Yes	
i) Suitable rear mudguards and Stone guards fitted for taillights	Yes	
j) Suitable size ladder fitted for the body cargo carrier.	Yes	
k) Chevrons and reflectors fitted on rear to conform to Kenya traffic act.	Yes	
l) All body steelwork to be thoroughly cleaned before painting. Both internal and exterior finish to be proceeded by one coat (red oxide) and undercoat.	Yes	
m) Truck to be painted in current Kenya Power paints specified by the user.	Yes (Mandatory)	
n) Properly safeguard and exposed number plate	Yes (Mandatory)	
8. ELECTRICAL SYSTEM/INSTRUMENTS		
a) System voltage, negative earth	24V	
b) Battery capacity and size	2x12V, 65AH	
c) Full lighting to conform to Cap 403, Subs 23-Kenya Traffic Act	Yes	
d) Standard instruments and gauges (or	Yes	
e) Warning lights) for charging circuit, oil Pressure, coolant temperature etc.	Yes	
9. EQUIPMENT		
a) Heavy duty type front fender	Yes	
b) Laminated (safety) windshield	Yes	

c) Sun visors supplied	Yes	
d) Rear view mirrors (external and internal) supplied	Yes	
e) Full size spare Tyre with rim and carrier mounted under truck.	Yes	
f) Hydraulic (telescopic) jack, wheel brace & manufacturer's standard tools,	Yes	
g) Hazard Triangles, First Aid KS-2094-2007 and 1 Kg fire extinguisher cylinder.	Yes, Mandatory	
h) Vehicle to be fitted with electronic speed governor	Yes, Mandatory	
i) Governor to limit maximum speed to 80km/hr and certificate provided.	Yes Mandatory	
j) Governor to be tamper proof	Yes	
k) Governor to be certified by Senior Transport Engineer before fitting	Yes Mandatory	
l) Engine immobilizes system fitted.	Yes	
m) Supply addition Loose Floor rubber mats.	Yes	
10.WARRANTY & FREE SERVICE		
a) Specimen of vehicle warranty to be submitted when tendering	Yes (Mandatory)	
b) Each vehicle supplied to carry a statement of warranty	Yes	
c) Vehicle warranty duration min. 12 Months	Specify (Months)	
d) 40,000Km whichever occurs first	Specify (Kms) (mandatory)	
e) Vehicle Free Service on Labour& Parts	Parts (Kms)	
	Labour (Kms)	
11.MANUALS		
a) All literature in the English language	Yes (Mandatory)	
b) Repair manuals, supplied	Yes (Mandatory)	
c) Parts catalogue/microfiche/CD, supplied	Yes (Mandatory)	
d) Drivers handbook supplied	Yes	
e) Service schedule supplied	Yes	
12.OTHER REQUIREMENTS		
a) Manufacturer's authorization supplied when tendering.	Yes (Mandatory)	
b) Evidence (in form of purchase documents) of minimum 10 units sold and serviced in Kenya.	Yes (Mandatory)	
c) Vehicle to be registered by Registrar of Motor Vehicles	Yes (Mandatory)	
d) Vehicle to be inspected by the KPLC Engineer prior to delivery	Yes (Mandatory)	
e) Franchise Holders and dealers who own fully fledged workshops with adequate equipment and facilities.	Yes (Mandatory)	
f) Body construction and all fitments to conform to Kenya Traffic Act CAP 403.	Yes (Mandatory)	
g) Chevrons and reflectors fitted on rear to conform to	Yes	

Kenya traffic act		
h) Car identity on all Glasses and Lights	Yes	
i) Indicate name and physical addresses of all Dealers / Agents where Genuine Spares and back-up service can be obtained in at least five (5) major Kenya Power depots (Nairobi, Mombasa, Kisumu, Nyeri, Nakuru and Eldoret).	Attach list Yes (Mandatory)	

HYDRAULIC HIGH LIFTING PLATFORM.

QUANTITY: 10

Specification No. **KPLC-TPT-03-17-18**

Description: Hydraulic Articulated & Telescopic High Lift Platform (Street lighting bucket).

Tenderers's name.....

	KPLC Requirements	
1. GENERAL.		
a) Make.	-	
b) Model.	-	
c) Country of origin.	-	
d) Manufacturer's Authorization Supplied as part of tender	Yes (mandatory)	
e) Manufacturer's Literature & Brochures Supplied as part of tender.	Yes (mandatory)	
f) Technical Specification Sheet fully completed and submitted.	Yes (mandatory)	
g) A standard production hydraulic Articulated and Telescopic high lifting platform, of latest design in the class, robust construction in current production and marketed in Kenya.	Yes (mandatory)	
h) Supplied new.	Yes (mandatory)	
i) Designed for heavy duty specifications, capable of operating in tropical conditions.	Yes	
2. DESIGN AND DIMENSIONS.		
a) Designed to export specifications suitable for fitting onto a Light truck.	Yes	
b) Working height Minimum, 15.0m	Yes(mandatory)	
c) Outreach minimum 6 mtrs	Yes(mandatory)	
d) Bucket to be easily accessible from deck in stowed position	Yes(mandatory)	
e) Maximum lifting capacity minimum 225kgs throughout the working envelope including at maximum outreach, tenderer to provide with tender drawings showing capacity performance throughout the working envelope graph.	Yes(mandatory)	
f) Swivel action angle minimum continuous rotation.	Yes(mandatory)	
g) Operator controllable bucket with single joystick type controls, attach supporting documentation.	Yes	
h) Minimum bucket operator insulation.	1000V Yes(mandatory)	
i) Hydraulically operated and independently controlled A-frame stabilizers for safety operation-4 units.	Yes(mandatory)	

j) Unit to incorporate interlock safety feature where platform cannot be operated unless all outriggers/stabilizers are down.	Yes(mandatory)	
k) Complete set of controls operation from the base, provide details with tender.	Yes (mandatory)	
l) Emergency power for platform which can be actuated by the operator from within the bucket and also from the lower controls station at base, attach supporting details and explain operations with tender.	Yes(mandatory)	
m) Emergency stop button at bucket and at bottom, attach details	Yes(mandatory)	
n) High performance hydraulic seals.	Yes (mandatory)	
o) Rated P.T.O pump output power min.	200 bars	
p) Suitable for high lifting on street lighting.	Yes	
q) Operations via Power take-off (P.T.O) pump with electro-pneumatic engage.	Yes(mandatory)	
r) Decking anti-slip chequered plate.	Yes	
s) Guard rail pipe all round	Yes	
t) Unit to be installed and integrated to supplied Light Truck Cab chassis	Yes	
u) Platform to meet all relevant International standards.	Yes(mandatory)	
v) Qty 2 LED flood light lamp provided (direction adjustable) and to be fitted onto top of truck body headboard on each side, individually controlled	Yes(mandatory)	
w) Tenderer to provide permanent earth point and to be fitted at the four corners of the load body (ball studs type earth point). Details to be submitted with tender.	Yes(mandatory)	
x) Tenderer to provide 2 units x 9kg “dry powder” fire extinguishers mounted onto vehicle body (one to be mounted on each side of the vehicle body with easy access from ground level).	Yes(mandatory)	
y) Five reflective stackable traffic cones to be supplied, minimum height 400mm	Yes(mandatory)	
z) Four outrigger pads with handles to be supplied, minimum size 400mm*400mm*40mm, attach details	Yes(mandatory)	
3. BUCKET:		
a) Number of persons to accommodate, minimum	2No. Yes (mandatory)	
b) Side panels at bottom of cage to prevent equipment spillage.	Yes(mandatory)	
c) GRP Glass reinforced all fiberglass bucket with hinged door, attach details	Yes(mandatory)	
d) Anti slip floor in bucket	Yes(mandatory)	
e) Bucket to have a beacon at the bottom, attach details	Yes(mandatory)	
f) System to fully deploy within 40 seconds	Yes	
g) Bucket to be fully insulated to min.1000V	Yes (mandatory)	
h) Bucket to have hooks for operator harness connection,	Yes (mandatory)	

attach details		
i) 4 point safety harness included, 2 units	Yes(mandatory)	
j) Operator luminous safety vest to be provided, 2 nos	Yes(mandatory)	
4. HIGH VOLTAGE SYSTEM AND HOUR METER.		
a) P.T.O engaging High voltage alert system fitted, attach manufacturers literature	Yes(mandatory)	
b) Nominal operating -5°C to +55°C	Yes	
c) Sound warning tone-85db	Yes	
d) Visual warning	Yes	
e) Detection range min. 50m	Yes(mandatory)	
f) Integrated diagnostic system with digital hydraulic pressure sensor, Hour meter and hydraulic pressure engaging fitted, attach manufacturers literature	Yes(mandatory)	
5. WARRANTY & FREE SERVICE.		
a) Specimen of platform warranty to be submitted when tendering	Yes(mandatory)	
b) Each platform supplied should carry a		
i. statement of warranty and test certificate	Yes (mandatory)	
ii. PTO pump manufacturers authorization	Yes(mandatory)	
iii. Platform warranty min., 12 Months or	Specify months	
iv. Platform Free Service on Labour& Parts	Parts (Hrs.)	
6. MANUALS:		
a) All literature in the English language	Yes (mandatory)	
b) Maintenance & service manuals supplied	Yes (mandatory)	
c) Parts catalogue supplied	Yes (mandatory)	
d) Operators handbook supplied	Yes	
e) Service schedule supplied	Yes	
7. OTHER REQUIREMENTS.		
a) Manufacturer's authorization supplied when tendering for the pressure engaging hour meter complete with integrated diagnostic.	Yes (mandatory)	
b) Manufacturers authorization supplied when tendering for the High Volt Alert System	Yes (mandatory)	
c) Manufacturers authorization supplied when tendering for the PTO pump.	Yes (mandatory)	
d) Evidence (in form of purchase documents) of minimum 10 units sold and serviced in Kenya.	Yes (Mandatory)	
e) Franchise Holders and dealers who own fully fledged workshop(s) equipment with adequate facilities.	Yes (Mandatory)	
f) Body construction and all fitments to conform to Kenya traffic act and to have a certificate from vehicle inspection centre.	Yes (mandatory)	
g) Crane to be inspected by the Senior Transport Engineer prior to delivery.	Yes (mandatory)	

h) Platform to be fitted onto the supplied Light truck.	Yes (mandatory)	
i) Indicate name and physical addresses of all Dealers/Agents where Genuine Spares and back-up service can be obtained in at least one major Kenya Power depots (Nairobi, Mombasa, Kisumu, Nyeri, Nakuru and Eldoret).	Attach list – Yes (mandatory)	

MEDIUM TRUCK, 4X2, 7.0 – 8.0 TON, CAB CHASSIS**Quantity: 15****Specification No. KPLC-TPT-04-17-18****Description: Medium truck 4x2, 7.0-8.0 Ton cab chassis complete with low sided body**

	KPLC Requirements	Tenderer's offer
1. GENERAL.		
a) Make	-	
b) Model	-	
c) Country of origin	-	
d) Manufacturer's Authorization Supplied	Yes (mandatory)	
e) Manufacturer's Literature & Brochures Supplied.	Yes (mandatory)	
f) Technical Specification Sheet fully completed and submitted.	Yes (mandatory)	
g) A standard production, 4x2, diesel utility medium truck of latest design in the class, robust construction in current production and marketed in Kenya.	Yes (mandatory)	
h) Supplied new.	Yes (mandatory)	
i) Control Forward/Normal	Specify	
j) Designed for heavy duty specifications, capable of operating in tropical conditions of mud and dust.	Yes (mandatory)	
k) Most suitable for operating on both "on and off" road conditions.	Yes (mandatory)	
l) Most suitable for fitting operating high lifting crane and cargo transportation as per the supplied drawing sheet.	Yes (mandatory)	
2. DIMENSIONS AND WEIGHTS.		
a) Overall length, min.	7,400 mm (mandatory)	
b) Overall width approx.	2,400 mm	
c) Overall height min.	2,500 mm	
d) Wheel base min.	4,200 mm (mandatory)	
e) Length of chassis after Cab, min.	5,300 mm (mandatory)	
f) Kerb weight min.	3,500 Kg (mandatory)	
g) Max. G.V.W. Approx.	13,500 Kg	
h) Payload, within range.	7,000 – 8,000 Kg (mandatory).	
i) Permissible front (steering) axle load, max	5,500kg (mandatory)	
j) Permissible rear (for dual wheels) axle load, max	8,500Kg (mandatory)	
k) Ground clearance, min	250 mm (mandatory)	
3. ENGINE.		
a) Make	-	
b) Model	-	

c) Country of origin	-	
d) Engine performance curves supplied	Yes	
e) Diesel Engine, water cooled, 4 stroke	Yes, (mandatory)	
f) Mode of aspiration. (Natural/Turbo)	Specify	
g) Piston displacement, within range.	7,000cc – 8,500 cc Yes(mandatory)	
h) Number of cylinders, min.	6 No. (mandatory)	
i) Maximum power output /rpm, min	180hp/3,000rpm Yes (mandatory)	
j) Maximum torque developed/rpm), min	500Nm/1800rpm Yes (mandatory)	
k) Air cleaner type, disposable/oil bath	Specify	
l) Oil and fuel filter type	Disposable	
m) Average fuel consumption (on full load)	Specify Kms/lit	
n) Fuel tank capacity, min.	200 Lts	
o) Extra fuel tank fitted capacity	Specify	
4. CLUTCH AND TRANSMISSION.		
a) Clutch, dry single plate,	Yes	
b) Clutch system actuation, Hydraulic	Yes	
c) Gearbox, synchromesh	Yes	
d) Number of speeds, min.	5F, 1R(mandatory)	
e) Drive configuration	4x2 Yes (mandatory)	
5. BRAKES AND TYRES.		
a) Brakes, hydraulic-pneumatic assisted	Yes (mandatory)	
b) Mechanical parking brake, to act on transmission	Yes	
c) Rear tyres	Dual	
d) Tyres size locally manufactured	Yes	
e) Optimum tyre size	Specify	
f) Suspension, front and rear heavy duty leaf springs with telescopic shock absorbers at front	Yes	
6. STEERING, CONTROL AND CAB.		
a) Right Hand Drive steering	Yes	
b) Steering type Manual/assisted	Power steering (Mandatory)	
c) Seat belts	Yes (Mandatory)	
7. BODY CONSTRUCION.		
a) Low-sided body as per the given drawing.	Yes (mandatory)	
b) Body cross bearers of pre-stressed channel sections, 100x50x4.5mm equidistantly spaced at a maximum of 500mm apart.	Yes	

c) Suitable size well-seasoned timber runners, with inverted steel section at top, between body frame and chassis.	Yes	
d) Body secured to chassis by U-bolts, diameter 16mm, held in position on wooden V-blocks.	Yes	
e) Body floor fabricated from 3.2mm thick mild steel plate (full width) reinforced at equal distances with box/channel sections.	Yes	
f) Steel platform body, made from mild steel chequered plate of thickness 3.2mm.	Yes	
g) Dropped tailgate and sides suitably reinforced.	Yes	
h) Suitable size toolbox to be fitted under body on the right-hand side.	Yes	
i) Fixed cargo carrier clear of cab to create suitable space for fitting crane machine as per the given drawing.	Yes	
j) Suitable rear mudguards fitted.	Yes	
k) Stone guards fitted for taillights.	Yes	
l) Suitable size ladder fitted for the body cargo carrier.	Yes	
m) Chevrons and reflectors fitted on rear to conform to Kenya traffic act.	Yes	
n) All body steelwork to be thoroughly cleaned before painting. Both internal and exterior finish to be proceeded by one coat (red oxide) and undercoat.	Yes	
o) Truck to be painted in current Kenya Power paints as specified by the user.	Yes (Mandatory)	
p) Body construction and all fitments to conform Cap 403 Kenya Traffic Act.	Yes (Mandatory)	
q) Properly safeguard and expose number plate	Yes (Mandatory)	
8. ELECTRICAL SYSTEM/INSTRUMENTS.		
a) System voltage, negative earth	24V Yes	
b) Battery capacity and size	Specify	
c) Full lighting to conform to Cap 403, subs 23-Kenya Traffic Act	Yes	
d) Standard instruments and gauges (or warning lights) for charging circuit, oil pressure, coolant temperature etc.	Yes	
9. EQUIPMENT.		
a) Heavy duty type front fender	Yes	
b) Laminated (safety) windshield	Yes	
c) Sun visors supplied	Yes	
d) Rear view mirrors (external both sides and internal) supplied	Yes	
e) Full size spare Tyre with rim and carrier mounted under truck	Yes	
f) Hydraulic (telescopic) jack, wheel brace & manufacturer's standard tools,	Yes,	

g) Any other equipment (or accessories) supplied	Specify	
h) Vehicle to be fitted with electronic speed governor	Yes (Mandatory)	
i) Governor to limit maximum speed to 80km/hr certificate provided.	Yes (Mandatory)	
j) Governor to be tamper proof	Yes (Mandatory)	
k) Governor to be certified by KPLC Engineer before fitting.	Yes (Mandatory)	
l) Engine immobilize system fitted	Yes	
m) Hazard Triangles metallic, Standard First Aid KS-2094-2007 and 1 Kg fire extinguisher.	Yes (Mandatory)	
n) Supply addition Loose Floor rubber mats	Yes	
10.WARRANTY.		
a) Specimen of vehicle warranty to be submitted when tendering	Yes	
b) Each vehicle supplied to carry a statement of warranty	Yes	
c) Vehicle warranty duration min. 12 Months 40,000Km	Specify Months	
d) Whichever occurs first	Specify Kms (mandatory)	
e) Vehicle Free Service on Labour & Parts	Parts (Kms)	
	Labour (Kms)	
11.MANUALS.		
a) All literature in the English language	Yes (mandatory)	
b) Repair manuals, supplied	Yes (mandatory)	
c) Parts catalogue/microfiche/CD, supplied	Yes (mandatory)	
d) Drivers handbook supplied	Yes (mandatory)	
e) Service schedule supplied	Yes (mandatory)	
12.OTHER REQUIREMENTS.		
a) Manufacturer's authorization supplied when tendering.	Yes (mandatory)	
b) Evidence (in form of purchase documents) of minimum 10 units sold and serviced in Kenya.	Yes (mandatory)	
c) Vehicle to be registered by Registrar of Motor Vehicles	Yes (mandatory)	
d) Vehicle to be inspected by the KPLC Engineer prior to delivery.	Yes (mandatory)	
e) Franchise Holders and dealers who own fully fledged workshops with adequate equipment and facilities.	Yes (Mandatory)	
f) Car identity on all Glasses and Lights.	Yes	
g) Body construction and all fitments to conform to Kenya Traffic Act CAP 403.	Yes (Mandatory)	
h) Chevrons and reflectors fitted on rear to conform to Kenya traffic act.	Yes	
i) Indicate name and physical addresses of all Dealers/Agents where Genuine Spares and back-up service can be obtained in at least four (5) major Kenya Power	Attach list Yes (Mandatory)	

depots (Nairobi, Mombasa, Kisumu, Nyeri, Nakuru and Eldoret).		
---	--	--

**6.0 TON (110kNm) LIFTING TRUCK MOUNTED CRANE
QUANTITY: 15**

Specifications: No KPLC-05-17-18

Description: 6.0 Ton (110kNm) Capacity Lifting truck Mounted knuckle boom crane complete with Augur bit & Hook.

Tenderer's name:.....

	KPLC Requirements	Tenderer's Offer
1. GENERAL.		
a) Make	-	
b) Model	-	
c) Country of origin	-	
d) Manufacturer's Authorization for Crane; Supplied with as part of tender	Yes (mandatory)	
e) Manufacturer's Catalogue & Brochures for Crane: Supplied as part of the tender.	Yes (mandatory)	
f) Technical Specification Sheet fully completed and submitted.	Yes (mandatory)	
g) A standard production, 6.0-ton (110kNm) truck mounted knuckle boom lifting crane of latest design in the class, robust construction in current production and marketed in Kenya.	Yes (mandatory)	
h) Supplied new.	Yes (mandatory)	
i) Crane to be fitted on the supplied Cab chassis with low dropside body truck	Yes (mandatory)	
2. DIMENSIONS AND WEIGHTS.		
a) Minimum Hydraulic Outreach standard	10.6m (mandatory)	
b) Lifting Capacity, min.	110kNm (mandatory)	
c) Hydraulic boom extension, min.	5.9m	
d) Extension cylinder pulling force	49-58KN	
e) Extension cylinder pushing force	42-51KN	
f) Outreach manual extension	12.8m (mandatory)	
g) Lifting height above installation level. Hydraulic /manual.	13.0/15.2m	
h) Outreach-Lifting Capacity, standard at 3.0 m, minimum	3,700kg (mandatory)	
i) Outreach-Lifting Capacity, standard at 4.5 m, minimum	2,500kg (mandatory)	
j) Outreach-Lifting Capacity, standard at 6.3 m, minimum	1,720kg (mandatory)	
k) Outreach-Lifting Capacity, standard at 10.3 m, minimum	1,000kg (mandatory)	
l) Rec. oil flow	45-50l/min.	
m) Working pressure, 28.0 MPa, , minimum	Yes (mandatory)	
n) Oil in tank	50L	
o) Maximum slope viable at full capacity	6° Yes (Mandatory)	
p) Slewing speed	15° m/s	
q) Max. Slope viable at full capacity	6°	

r) Slewing torque, gross	16.4KNm	
s) Slewing angle, minimum 415°	Yes (mandatory)	
t) Lifting speed at standard hydraulic outreach and rec. oil flow	1.7m/s	
u) Height in folded position	2200 mm	
v) Width in folded position	2500 mm	
w) Installation space needed max. 1000mm	Yes (mandatory)	
x) Tiltable and extendable stabilizer legs	Yes (mandatory)	
y) Minimum extension of Stabilizer legs 5.5m, attach details	Yes (mandatory)	
z) Qty 2 LED flood light lamp provided (direction adjustable) and to be fitted onto top of truck body headboard, one on each side, individually controlled	Yes (mandatory)	
3. WEIGHTS & CONTROLS		
a) Weight of lifting crane in standard version including hydraulic extensions without support legs, maximum 1600kg.	Specify, Yes (Mandatory)	
b) Frame attachments	32-65Kg	
c) Support leg equipment.	195-366kg	
d) Power Take off.	Yes (mandatory)	
e) High performance pump, min 270 Bars	Yes (mandatory)	
f) Anchoring Bolts	Yes	
g) High Pressure hoses	Yes (mandatory)	
h) Crane performance – 6 Function Remote control (wireless) system for crane operation and one set of manual controls at crane base, attach supporting documentation	Yes (mandatory)	
i) Remote control unit to include battery charger for the rechargeable battery and a Neck belt for comfortable operator use, spare battery to be provided	Yes (mandatory)	
j) Crane will include Load Bearing valves	Yes	
k) Crane will include Load Failure Valves.	Yes	
l) After Sales service	Yes (mandatory)	
m) Test Certificate for crane supplied	Yes (mandatory)	
n) One year minimum warranty	Yes (mandatory)	
4. HIGH VOLTAGE ALERT SYSTEM		
a) High Volt Alert system fitted (attach manufacturers literature).	Yes (mandatory)	
b) PTO engaging high voltage alert system	Yes (mandatory)	
c) Nominal operating temperature within range -5° to +55°	Yes (mandatory)	
d) Sound warning tone, max.	85db Yes (mandatory)	
e) Visual warning	Yes (mandatory)	
f) Detection range min. 50m	Yes (mandatory)	

5. HYDRAULIC POLE TAMPER.		
a) Hydraulic powered (from crane hydraulics) pole tamper attach details and literature.	Yes (mandatory)	
b) Capacity: 75mm x 200mm kidney shoe	Yes (mandatory)	
c) 9000mm high pressure hydraulic hose complete with quick couplings	Yes (mandatory)	
d) Performance, 1600blows per minute, min.	Yes (mandatory)	
e) Pressure 70-140Bars	Yes	
f) Flow range: 11-34 litres per minute	Yes	
g) Weight, max.	14 Kgs Yes (mandatory)	
h) Control valve on tamper handle for on/off operation by the operator at the pole tamper	Yes (mandatory)	
i) Stroke, min.	60mm Yes (mandatory)	
j) Length of pole Tamper	1.7m-1.9m Yes mandatory)	
6. AUGUR BIT AND QUICK TOOL CHANGER.		
a) Auger and its accessories supplied, (attach literature)	Yes (mandatory)	
b) Heavy duty planetary drive	Yes (mandatory)	
c) Bi-directional	Yes (mandatory)	
d) Auger max Torque, min 5500NM @240 Bar, attach details	Yes (mandatory)	
e) Complete with extensions and Augur bits	Yes (Mandatory)	
f) Depth of drilling, min.	2000mm (Mandatory)	
g) Drilling diameter	400mm Yes (Mandatory)	
h) Drilling bits performance to suit local conditions of earth and clay (soft to medium soils), bits to be Tungsten carbide tips, attach technical literature.	Yes (Mandatory)	
i) Storage tray bolted onto truck body platform to secure Augur drive, Augur bit and Augur Extension	Yes (Mandatory)	
j) Quick change facility, Quick tool changer tool changer hydraulic system (whereby no manual operator contact is required) with intergrated lifting hook, attach literature	Yes (Mandatory)	
k) Adapters for the Augur and hook and the rotating mechanism	Yes (Mandatory)	
l) Storage facility for the quick tool changer	Yes (Mandatory)	
m) Tool changer weight of 70-120Kgs	Yes (mandatory)	
n) Catalogues for Augur bit and Quick tool changer included with tender	Yes (Mandatory)	
7. EQUIPMENT AND OTHER ACCESSORIES.		
a) Integrated diagnostic system with digital hydraulic pressure sensor, Hour meter and hydraulic pressure engaging fitted (Attach manufacturers literature)	Yes (mandatory)	

b) Maintenance & service manual.	Yes (mandatory)	
c) Operational manual.	Yes (mandatory)	
d) Spare parts catalogue.	Yes (mandatory)	
e) Manual Extension suitable to be attachable to crane and to be used in operations to securely retain poles when propping leaning poles, this extension to include additional swivelling crane hook (7000kg capacity), attach drawings and literature	Yes (Mandatory)	
f) Tenderer to provide permanent earth point and to be fitted at the four corners of the load body (ball studs type earth point). Details to be submitted with tender.	Yes (mandatory)	
g) Two outrigger pads with handles to be supplied, minimum size 400mm*400mm*40mm, attach details	Yes (mandatory)	
h) Five reflective stackable traffic cones to be supplied, minimum height 400mm	Yes (mandatory)	
i) Operator luminous safety vest to be provided, 2 nos	Yes (mandatory)	
8. WARRANTY & FREE SERVICE.		
a) Specimen of crane warranty to be submitted when tendering.	Yes (mandatory)	
b) Each crane supplied to carry a statement of warranty.	Yes (mandatory)	
c) Truck mounted crane warranty duration min. 12 Months	Specify Months	
200 Hours whichever occurs first	Specify Kms Yes (mandatory)	
d) Crane Free Service on Labour& Parts	Parts (Kms)	
	Labour (Kms)	
9. MANUALS.		
a) All literature in the English language	Yes (mandatory)	
b) Repair manuals, supplied	Yes (mandatory)	
c) Parts catalogue/microfiche/CD, supplied	Yes (mandatory)	
d) Operator's handbook supplied	Yes	
e) Service schedule supplied	Yes	
f) Operator Training included	Yes (mandatory)	
g) Crane test certificate provided	Yes (mandatory)	
10. OTHER REQUIREMENTS.		
a) Manufacturers' authorization supplied when tendering for the pressure engaging hour meter complete with integrated diagnostic.	Yes (mandatory)	
b) Manufacturers authorization supplied when tendering for the High Volt alert System	Yes (mandatory)	
c) Manufacturers Authorization supplied when tendering for the PTO Pump.	Yes (mandatory)	
d) Evidence (in form of purchase documents) of minimum 10	Yes (Mandatory)	

units sold and serviced in Kenya.		
e) Franchise Holders and dealers who own fully fledged workshop(s) equipment with adequate facilities.	Yes (Mandatory)	
f) Body construction and all fitments to conform to Kenya traffic act and to have a certificate from vehicle inspection centre.	Yes (mandatory)	
g) Crane to be inspected by the KPLC Engineer prior to delivery.	Yes (mandatory)	
h) Crane to be fitted onto the supplied cab chassis truck with low dropside body.	Yes (mandatory)	
i) Indicate name and physical addresses of all Dealers/Agents where Genuine Spares and back-up service can be obtained in at least one major Kenya Power depots (Nairobi, Mombasa, Kisumu, Nyeri, Nakuru and Eldoret).	Attach list – Yes (mandatory)	

5.0 TON LIFTING CAPACITY FORKLIFT.**QUANTITY: 2****Specification No:KPLC-TPT-17-16-17****Description: 5.0 Ton capacity Fork Lift.****Tenderers' name.....**

	KPLC Requirements	Tenderer's Offer
1. GENERAL.		
a) Make	-	
b) Model	-	
c) Country of origin	-	
d) Manufacturer's Authorization Supplied	Yes (mandatory)	
e) Manufacturer's Literature & Brochures Supplied.	Yes (mandatory)	
f) Technical Specification Sheet fully completed and submitted.	Yes (mandatory)	
g) A standard production Diesel propelled Fork lift of latest design in robust construction in current production marketed in Kenya	Yes (mandatory)	
h) Supplied new.	Yes (mandatory)	
i) Designed for heavy duty specifications, capable of operating in a limited space, inside a standard transportation container.	Yes (mandatory)	
2. WEIGHTS.		
a) Maximum Load capacity at load centre of 600mm.	5000Kg Yes (Mandatory)	
b) Un laden weight without load, front/rear min.	3000Kg/4000Kg	
c) Axle loading with load, front/rear min.	11000Kg/1200Kg	
d) Service weight approx.	7000Kg, Yes	
3. WHEELS AND TYRES.		
a) Tyres: Industrial solid tyres	Yes(Mandatory)	
b) Wheels, 4No Front(driven) and 2No Rear	Yes(Mandatory)	
c) Track width front, max.	1790mm	
d) Track width rear, max.	1270mm	
e) Tyres, single drive, Drive, 300 x 15	Yes (mandatory)	
f) Tyres, single drive, Drive, 7.00 x 15	Yes (mandatory)	
4. DIMENSIONS.		
a) Wheelbase min.	2100mm Yes (Mandatory)	
b) Mast/Fork tilts, forward max.	15°	
c) 2 Stage clear view cut mast, overall height, max.	4100mm	
d) Free lift, min.	1000mm	
e) Mast/Fork tilt, backward max.	12°	
f) Overall height, mast lowered, max.	2300mm	
g) Free lift	Specify	
h) Lift height min.	4100mm	

i) Height of mast, extended.	Specify	
j) Cab height approx. min.	2300mm	
k) Seat height approx. min.	1200mm	
l) Towing coupling height, min.	500mm	
m) Overall length, min.	4500mm	
n) Length to face of forks min.	3300mm	
o) Fork carriage width, min.	1500mm Yes (Mandatory)	
p) Fork carriage length, min.	1800mm Yes (Mandatory)	
q) Ground clearance under mast, with load min.	190mm Yes (Mandatory)	
r) Ground clearance, centre of wheelbase min.	230mm Yes (Mandatory)	
s) Outer turning radius approx. min.	2900mm	
t) Inner turning radius min.	1300mm	
5. PERFORMANCE.		
a) Travel speed with/without load.	Specify	
b) Lifting speed with/without load	Specify	
c) Lowering speed with/without load.	Specify	
d) Transmission-3-speed hydrodynamic	Yes (mandatory)	
e) Hydraulic service brake	Yes (mandatory)	
6. ENGINE.		
a) Engine manufacture/type	Specify	
b) Engine output, within range.	55-60Kw@2400rpm Yes (mandatory)	
c) Power: Diesel	Yes (Mandatory)	
d) Engine torque approx.	500Nm/1200rpm	
e) Turning speed approx.	2000rpm	
f) Number of cylinders.	4 Yes (mandatory)	
g) Engine capacity (displacement) within range.	3500cc-4000cc. Yes (Mandatory)	
7. ACCESSORIES.		
a) Maintenance & Service manual	Yes	
b) Operational Manual	Yes	
c) Spare Parts Catalogue	Yes	
d) Repair Manuals	Yes	
e) Supply complete with 2 No. spare wheels, wheel spanner and hydraulic bottle jack.	Yes (Mandatory)	
8. OTHER REQUIREMENTS.		
a) Manufacturers' authorization supplied when tendering.	Yes (mandatory)	
b) Evidence (in form of purchase documents) of minimum 10 units sold and serviced in Kenya.	Yes (Mandatory)	
c) Franchise Holders and dealers who own fully fledged workshop(s) equipment with adequate facilities for servicing the equipment. Attach proof of ownership/lease and list of equipment installed	Yes (Mandatory)	
d) Body construction and all fitments to conform to Kenya traffic act and to have a certificate from vehicle inspection	Yes (mandatory)	

center.		
e) Plant to be inspected by the KPLC Engineer prior to delivery.	Yes (mandatory)	
f) Indicate name and physical addresses of all Dealers/Agents where Genuine Spares and back-up service can be obtained in at least one major Kenya Power depots (Nairobi, Mombasa, Kisumu, Nyeri, Nakuru and Eldoret).		

8.0 TON LIFTING CAPACITY FORKLIFT.**QUANTITY: 1****Specification No:KPLC-TPT-18-16-17****Description: 8.0 Ton capacity Fork Lift.****Tenderers' name.....**

	KPLC Requirements	Tenderer's Offer
1. GENERAL		
a) Make	-	
a) Model	-	
b) Country of origin	-	
c) Manufacturer's literature/brochures and specification supplied.	Yes (Mandatory)	
d) A standard production, 8.00 Ton Fork lift of latest design in robust construction in current production marketed in Kenya	Yes (Mandatory)	
e) Supplied new	Yes (Mandatory)	
f) Designed to heavy-duty export specs, capable of operating in tropical conditions.	Yes	
2. WEIGHTS.		
a) Load capacity/rated load, min.	8000Kg Yes (Mandatory)	
b) Un laden (service) weight min.	11000Kg	
c) Axle loading with load, front/rear min.	17000Kg/2000Kg	
d) Axle loading without load, front/rear min.	5000Kg/6000Kg	
3. WHEELS AND TYRES.		
a) Tyres: Industrial solid tyres	Yes (Mandatory)	
b) Wheels, 4 No front (driven) and 2 No rear	Yes (Mandatory)	
c) Track width front min.	2100mm	
d) Track width rear min.	1600mm	
4. DIMENSIONS.		
a) Wheelbase min.	2400mm Yes (Mandatory)	
b) Mast/Fork tilts, forward max.	15°	
c) Mast/Fork tilt, backward max.	12°	
d) Height, mast lowered approx.	4000mm	
e) Free lift	Specify	
f) Lift height min.	5500mm Yes (Mandatory)	
g) Height of mast, extended.	Specify	
h) Cab height approx. min.	2600mm	
i) Seat height approx. min.	1600mm	
j) Towing coupling height min.	500mm	
k) Overall length min.	4880mm	
l) Length to face of forks min.	3650mm	

m) Fork carriage width, min.	2000mm	Yes (Mandatory)	
n) Fork carriage length, min.	1800mm	Yes (Mandatory)	
o) Ground clearance under mast, with load approx. min.	200mm		
p) Ground clearance, center of wheelbase min.	250mm		
q) Outer turning radius approx. min.	3200mm		
r) Inner turning radius approx. min.	1400mm		
5. PERFORMANCE.			
a) Travel speed with/without load.	Specify		
b) Lifting speed with/without load	Specify		
c) Lowering speed with/without load.	Specify		
d) Transmission-3-speed hydrodynamic	Yes (mandatory)		
e) Hydraulic service brake	Yes (mandatory)		
6. ENGINE.			
a) Engine manufacture/type	Specify		
b) Engine output within range.	80-90Kw/2400rpm	Yes (mandatory)	
c) Power: Diesel	Yes (Mandatory)		
d) Engine torque approx.	500Nm/1200rpm		
e) Turning speed approx.	2000rpm		
f) Number of cylinders.	4Cylinders		
g) Engine capacity (displacement) within range.	3500cc-4500cc.	Yes(Mandatory)	
7. ACCESSORIES.			
a) Maintenance & Service manual	Yes		
b) Operational Manual	Yes		
c) Spare Parts Catalogue	Yes		
d) Repair Manuals	Yes		
e) Supply complete with 2 No. spare wheels, wheel spanner and hydraulic bottle jack.	Yes(Mandatory)		
8. OTHER REQUIREMENTS.			
a) Fork lift to be registered by Registrar of Motor Vehicles	Yes (mandatory)		
b) Fork lift to be inspected by the Chief Transport engineer prior to delivery	Yes (mandatory)		
c) Firm's status: Franchise/Dealer/Agent	Specify		
d) Indicate name and physical addresses of all Dealers/Agents where Genuine Spares and back-up service can be obtained In At least four major Kenya Power depots (Nairobi, Mombasa, Kisumu, Nyeri, Nakuru and Eldoret).	Attach list - At least four major KPLC depots (mandatory)		
e) Body construction and all fitments to conform Cap 403 Kenya Traffic Act.	Yes (Mandatory)		

3-WHEEL LOGGER- LOADER.**QUANTITY: 3****Specifications: No: KPLC-TPT-08-17-18****Description: 3-Wheel logger-loader****Tenderer's name:.....**

	KPLC Requirements	
1. GENERAL.		
a) Manufacturer's Authorization Supplied	Yes (mandatory)	
b) Manufacturer's Literature & Brochures Supplied.	Yes (mandatory)	
c) Technical Specification Sheet fully completed and submitted.	Yes (mandatory)	
d) A standard production, 3-wheel logger -loader of latest design in robust construction in current production marketed in Kenya.	Yes, (Mandatory)	
e) Supplied new.	Yes (mandatory)	
f) Designed to heavy-duty export specs, capable of operating in tropical conditions on paved and unpaved surface.	Yes, (Mandatory)	
2. ENGINE.		
g) Engine displacement, within range.	3000-4000cc Yes (Mandatory)	
h) Engine configuration: Four Cylinder in-line	Yes	
i) Cooling System: Air cooled by engine fan drive	Yes	
j) Net Power.	49w(60hp)@2000rpm Yes (Mandatory)	
k) Max Torque achieved.	230Nm @1600rpm Yes (Mandatory)	
3. TRANSMISSION.		
a) Pump: Vickers TA1919	Yes	
b) Type: Variable displacement tandem axial piston pump	Yes	
c) Controls: Direct linkage via foot pedals	Yes	
d) Rating Pressure approx.:	30,000 kPa (Yes)	
e) Flow rate approx.	85 l/min@2100rpm Yes (Mandatory)	
f) Motors:	Specify	
g) Type: Axial Piston	Yes	
h) Rating Pressure:	31000kPa (4500psi)	

	Yes, (Mandatory)	
i) Rating Flow:	80 l/min @2000rpm	Yes
j) Wheel drives: Double Planetary reduction in series	Specify	
k) Configuration: Double planetary reduction in series with planetary reduction gears.	Yes	
l) Reduction Ratio approx.:	67:1	Yes
m) Travel Speed:	9.5km/h	Yes
n) Tractive effort:	32.3KN	Yes
4. HYDRAULIC SYSTEM AND EQUIPMENT.		
a) Operating weights min.	5090Kg	Yes
b) Grapple capacity, min.	0.35m ²	Yes (Mandatory)
c) Grapple rotator-heavy duty 5-ton continuous rotator	Yes	(Mandatory)
d) Pumps: Open centre dual circuit.	Yes	
e) Type: Fixed displacement van pump	Yes	
f) Application: Grapple, rotator and tele-boom	Yes,	(Mandatory)
g) Operating pressure:	13800kPa (2000 psi)	Yes, (Mandatory)
h) Type: Fixed displacement gear pump	Yes	
i) Application: Attachments	Yes	
j) Flow rate:	35 l/min @2000 rpm	Yes
k) Pressure, min:	1500 kPa	Yes, (Mandatory)
5. STEERING SYSTEM.		
a) Treadle control system	Specify	
b) Front wheel hydraulic skid steer via foot operated treadle control system.	Yes,	(Mandatory)
6. BOOM MAST.		
a) Teleboom	Yes,	(Mandatory)
7. CABIN.		
a) Type: Integral with steel frame. No doors.	Yes,	(Mandatory)
b) Guarding: HD windscreen guard & bonnet guard	Yes,	(Mandatory)
c) Ventilation: Open ventilation	Yes,	(Mandatory)
8. ACCESSORIES.		
a) Tool kits and other standard tools	Yes	
b) vehicle accessories	Yes	
c) Identity markings to included	Yes	
d) Floor Mats	Yes	

e) Fire Extinguisher	Yes	
f) First Aid Kit	Yes	
g) 2 No spares catalogue	Yes	
h) 2 No Operational Manual	Yes	
i) 2 No Repair Manuals	Yes	
9. OTHER REQUIREMENTS.		
a) Manufacturer's authorization supplied when tendering.	Yes (mandatory)	
b) Evidence (in form of purchase documents) of minimum 10 units sold and serviced in Kenya.	Yes (mandatory)	
c) 3-Wheel loader to be registered by Registrar of Motor Vehicles.	Yes (mandatory)	
d) 3-Wheel loader to be inspected by the Chief Transport engineer prior to delivery.	Yes (mandatory)	
e) Body construction and all fitments to conform Cap 403 Kenya Traffic Act.	Yes (Mandatory)	
f) Indicate name and physical addresses of all dealers/agents where Genuine Spares and back-up service can be obtained in at least one major Kenya Power depots (Nairobi, Mombasa, Kisumu, Nyeri, Nakuru and Eldoret).	Attach list -	

PRIME MOVER, 6X4, COMPLETE WITH LOGGING-SEMI-TRAILER.**QUANTITY: 1****Specification No. KPLC-TPT-09-17-18.****Description: Prime mover, 6x4, Diesel, Complete with standard-logging-semi-trailer.****Tenderers's name.....**

	KPLC Requirements	Tenderer's
1. GENERAL.		
a) Make	-	
b) Model	-	
c) Country of origin	-	
d) Manufacturer's Authorization Supplied	Yes (Mandatory)	
e) Manufacturer's Literature & Brochures Supplied.	Yes (Mandatory)	
f) Technical Specification Sheet fully completed and submitted.	Yes (Mandatory)	
g) A standard production, 6x4, Diesel utility Prime mover complete with 30.0-ton capacity, 12m (40") long, three rear axles logging-semi-trailer of latest design in robust construction in current production and marketed in Kenya.	Yes (Mandatory)	
h) Prime mover (tractor) suitable for fitting 16.0-ton high lifting log-lift crane after cab chassis as per the supplied drawing sheet.	Yes (Mandatory)	
i) Designed to heavy-duty export specifications, capable of pulling 12m long logging-semi-trailer over paved and unpaved roads.	Yes (Mandatory)	
j) Supplied new.	Yes (Mandatory)	
k) Standard logging-semi-trailer locally manufactured.	Yes (Mandatory)	
l) Control Forward/Normal	Specify	
2. DIMENSIONS AND WEIGHTS.		
a) Overall length, min.	6600 mm Yes (Mandatory)	
b) Coupler offset, min.	300mm Yes (Mandatory)	
c) Front fitting radius, min.	2700mm Yes (Mandatory)	
d) Lower fitting radius, min.	2000 Yes (Mandatory)	
e) Coupler height	1420mm Yes (Mandatory)	
f) Overall width, min.	2400 mm, Yes	
g) Overall Height, min.	2850 mm (Mandatory)	
h) Wheel base approx.	4,200 mm	

	Yes (Mandatory)	
i) Cab to rear axle centre, min.	3,000mm Yes (Mandatory)	
j) Kerb weight approx.	8,100 Kg	
k) g) Max. G.V.W. approx.	28,000Kg. (Mandatory)	
l) Max. G.C.W. approx.	50,000Kg Yes (Mandatory)	
m) Ground Clearance, min.	260 mm (Mandatory)	
n) Min. turning radius (tractor only)	7.0m (Mandatory)	
3. ENGINE.		
a) Make	-	
b) Model	-	
c) Country of origin	-	
d) Engine performance curves supplied	Yes	
e) Diesel Engine, water cooled, 4 stroke cycle	Yes (Mandatory)	
f) Mode of aspiration. (Natural/Turbo)	Specify	
g) Piston displacement, min.	11,900cc Yes (mandatory)	
h) Number of cylinders, 8/12	Specify	
i) Maximum power output /rpm, min	220Kw/2000rpm. Yes (Mandatory)	
j) Maximum torque developed/rpm), min.	1200Nm/1200rpm. Yes (Mandatory)	
k) Air cleaner type, disposable/oil bath	Specify	
l) Maximum engine speed, min.	2300rpm	
m) Oil and fuel filter type	Disposable	
n) Average fuel consumption (on full load)	Specify Kms/Lit.	
o) Fuel tank capacity, min.	360 Litres	
4. CLUTCH AND TRANSMISSION.		
a) Clutch, dry single plate, coil spring type	Yes	
b) Clutch system actuation, Hydraulic	Yes	
c) Gearbox, synchromesh	Yes	
d) Number of speeds, min.	8F, 2R Yes (Mandatory)	
e) Drive configuration	6x4 Yes (mandatory)	
5. BRAKES TYRES AND SUSPENSION.		
a) Brakes hydraulic-pneumatic assisted, Exhaust brakes, Trailer brakes, and Parking brakes.	Yes	
b) Mechanical parking brake, to act on transmission	Yes	
c) Rear tyres	Dual	
d) Tyres size locally manufactured	Yes	
e) Optimum tyre size	Specify	

f) Suspension, front and rear heavy-duty leaf springs with telescopic shock absorbers at front. Trunion type suspension at rear.	Yes	
6. STEERING, CONTROL AND CAB.		
a) Right Hand Drive steering	Yes	
b) Power assisted steering type	Yes (mandatory)	
c) All steel, spacious cab to seat 3 passengers comfortably	Yes	
d) Adjustable driver's seat.	Yes	
e) Seat belts.	Yes	
7. LOGGING SEMI-TRAILER FITTINGS AND FABRICATION.		
a) A standard production, open side, 40'' long logging semi-trailer complete with three braked axle suitable for transporting poles.	Yes (mandatory)	
b) 12No. Standard container securing hooks to hold the side supporting beams.	Yes (mandatory)	
c) 6No. side supporting beams complete with fastening chain hooks	Yes (mandatory)	
d) Platform body floor made of mild steel plate of 3mm thickness.	Yes (mandatory)	
e) Fixed front, middle and rear supporting beams fully reinforced at the edges.	Yes (mandatory)	
8. ELECTRICAL SYSTEM/INSTRUMENTS.		
a) System voltage, negative earth	24V	
b) Battery capacity and size	2x12v, 150AH	
c) Full lighting to conform to Cap 403, subs 23-Kenya Traffic Act	Yes	
d) Standard instrumentation panels and all operational control switches.	Yes	
9. EQUIPMENT.		
a) Heavy duty type front fender.	Yes	
b) 2 No. spare wheels.	Yes (mandatory)	
c) Sun visors supplied two.	Yes	
d) Rear view mirrors (external and internal) supplied	Yes	
e) Full size spare tyres with rim and carrier for the semi-trailer.	2No. Yes (mandatory)	
f) Heavy duty hydraulic (telescopic) jack, wheel brace & manufacturer's standard tools,	Yes	
g) Hazard Triangles, First Aid kit KS-2094-2007 and fire extinguisher.	Yes (mandatory)	
h) Vehicle to be fitted with electronic speed governor.	Yes (mandatory)	
i) Governor to limit maximum speed to 80km/hr.	Yes (mandatory)	
j) Governor to be tamper proof.	Yes (mandatory)	

k) Governor to be certified by CM&TE before fitting.	Yes (mandatory)	
l) Engine immobilizer system fitted.	Yes	
m) Supply additional Loose Floor rubber mats.	Yes	
n) Provide loose Tyre inflating hose pipe (at least 20 meters long)	Yes (mandatory)	
o) Chevrons and reflectors fitted on rear to conform to Kenya traffic act.	Yes	
p) Car identity on all Glasses and Lights.	Yes	
10.WARRANTY & FREE SERVICE.		
a) Specimen of vehicle warranty to be submitted when tendering	yes	
b) Each vehicle supplied to carry a statement of warranty	Yes	
c) Vehicle warranty duration min. 12 Months	Specify (months)	
d) 40,000Km whichever occurs first	Specify (KMS) (mandatory)	
e) Vehicle Free Service on Labour & Parts	Parts (Kms)	
	Labour (Kms)	
11.MANUALS.		
a) All literature in the English language.	Yes (mandatory)	
b) Repair manuals/ microfiche/CD, supplied.	Yes (mandatory)	
c) Parts catalogue/microfiche/CD supplied.	Yes (mandatory)	
d) Driver's handbook supplied.	Yes	
e) Service schedule supplied.	Yes (mandatory)	
12.OTHER REQUIREMENTS.		
a) Manufacturer's authorization supplied when tendering.	Yes (mandatory)	
b) Evidence (in form of purchase documents) of minimum 10 units sold and serviced in Kenya.	Yes (Mandatory)	
c) Franchise Holders and dealers who own fully fledged Workshops with adequate equipment and facilities.	Yes (Mandatory)	
d) Body construction and all fitments to conform to Kenya traffic act and to have a certificate from vehicle inspection centre.	Yes (mandatory)	
e) Prime mover to be inspected by the KPLC Engineer prior to delivery.	Yes (mandatory)	
f) Prime mover and semi-trailer to be registered by Registrar of Motor Vehicles prior delivery.	Yes (mandatory)	
g) Indicate name and physical addresses of all Dealers/Agents where genuine spares and back-up service can be obtained in at least four (5) major Kenya Power depots (Nairobi, Mombasa, Kisumu, Nyeri, Nakuru and Eldoret).	Attach list – Yes (mandatory)	

3.5 TON TRUCK MOUNTED LIFTING CRANE COMPLETE WITH GRAPPLE.**QUANTITY: 1****DESCRIPTION: 3.5 Ton (150 kNm) capacity log lifting crane complete with grapple****SPECIFICATIONS: KPLC-TPT-10-17-18****TENDERER'S NAME:.....**

	KPLC Requirements	Tenderer's Offer
1. GENERAL.		
a) Make		
b) Model		
c) Country of Origin		
d) Manufacturer's Authorization for both Crane & Grapple Supplied	Yes (mandatory)	
e) Manufacturer's Literature & Brochures for both Crane & Grapple Supplied.	Yes (mandatory)	
f) Technical Specification Sheet fully completed and submitted.	Yes (mandatory)	
g) A standard production, high capacity log lifting Truck mounted knuckle boom crane of latest design in robust construction in current production and marketed in Kenya.	Yes (mandatory)	
h) Supplied new and be fitted onto the supplied 6x4, Prime mover.	Yes (mandatory)	
i) Suitable crane ready to operate with the Pole Grapple.	Yes (mandatory)	
2. DESIGN AND CONSTRUCTION.		
a) Lifting Capacity, min.	150KNm Yes (mandatory)	
b) Equipment to be fitted on a supplied 6x4, Prime mover chassis.	Yes.	
c) Minimum Hydraulic Outreach standard.	9.0m Yes (mandatory)	
d) Hydraulic boom extension, min.	9.0m	
e) Recoil flow	70-90littres/min	
f) Working pressure	22.0 Mpa	
g) Outreach manual extension	12.8m	
h) Lifting height above installation level. Hydraulic /manual.	10.0/12.2m	
i) Outreach-Lifting Capacity, standard at 3.8m	3550Kgs (mandatory)	
j) Outreach- Lifting Capacity, standard at 5.0m	2950kg (mandatory)	

k) Outreach- Lifting Capacity, standard at 7.0m	2200kg (mandatory)	
l) Outreach-Lifting Capacity, standard at 8.0m	1850kg (mandatory)	
m) Rec. oil flow	70-90l/min.	
n) Max working pressure	22MPa Yes (mandatory)	
o) Oil in tank	45L	
p) Tank capacity	60L	
q) Slewing angle max.	415°-430°	
r) Max. Slope viable at full capacity.	5 °	
s) Slewing torque, gross.	31KNm Yes (mandatory)	
t) Slewing speed.	15m/s	
u) Lifting speed at standard hydraulic outreach and rec. oil flow	0.7m/s-5.3m	
v) Height in folded position	2508mm	
w) Width in folded position	2500mm	
x) Installation space needed	1095mm	
y) Top seat included with adjustable seat height	Yes (mandatory)	
z) Log heel	Yes (mandatory)	
3. WEIGHTS.		
a) Loader in standard version without support legs.	1800-2100Kg (mandatory)	
b) Top seat	135Kg	
c) Frame attachments	Specify	
d) Support leg equipment	395kg	
e) Oil tank	36kg	
f) Power Take off	Yes (mandatory)	
g) High performance pump	270 Bars Yes (mandatory)	
h) Flow rate	55 liters/Min Yes (mandatory)	
i) Crane performance –top seat	Yes (mandatory)	
j) Anchoring Bolts	Yes	
k) High Pressure hoses	Yes	
l) Crane performance - Both sides	Yes	
m) Identical lever sequence shown	Yes	
n) Crane will include Load Bearing Valves	Yes	
o) Crane will include Load Failure Valves	Yes	
p) After Sales service	Yes	
q) Test Certificate for crane Offered	Yes	
4. HIGH VOLT ALERT SYSTEM.		
a) PTO engaging high volt alert system	Yes (mandatory)	

b) Nominal operating temperature -5°C to +55°C	Yes	
c) Sound warning tone-85db	Yes	
d) Visual warning	Yes	
e) Detection range-50m	Yes	
f) Manufacturers authorization for the High Volt Alert System	Yes (mandatory)	
5. POLE GRAPPLE AND ROTATOR		
a) 2 function coupled heavy duty rotating grapple for timber	Yes (mandatory)	
b) Max weight of rotator and grapple	275kgs – 325Kgs Yes (mandatory)	
c) Rotator slewing angle	360°	
d) Grapple capacity, minimum	1000Kgs Yes (mandatory)	
e) Fixed grapple connection with folding with crane	Yes (mandatory)	
f) Grapple safety brake	Yes (mandatory)	
g) Grapple capable of handling 40' wooden poles	Yes (mandatory)	
h) Grapple holding area minimum 0.4 m ²	Yes (mandatory)	
i) Grapple jaw pressure minimum 19.6 kN	Yes (mandatory)	
j) Catalogue	Yes (mandatory)	
6. ACCESSORIES.		
a) Maintenance & Service manual	Yes	
b) Operational Manual	Yes	
c) Spare Parts Catalogue	Yes	
d) Integrated diagnostic system with digital hydraulic pressure sensor, Hour meter and hydraulic pressure engaging fitted, attach literature.	Yes (mandatory)	
e) Manufacturers Authorization for Hour Meter	Yes (mandatory)	
f) LED flood light provided installed onto crane lighting in direction of a crane tip operations.	Yes (mandatory)	
7. WARRANTY AND FREE SERVICE		
a) Specimen of crane warranty to be submitted when tendering.	Yes (mandatory)	
b) Each crane supplied to carry a statement of warranty.	Yes (mandatory)	
c) Truck mounted crane warranty duration min. 12 Months /	Specify Months	
200 hours whichever occurs first.	Specify Kms Yes (mandatory)	
Crane Free Service on Labour & Parts	Parts (Kms) Labour (Kms)	
8. MANUALS		
a) All literature in the English language	Yes (mandatory)	

b) Repair manuals, supplied	Yes (mandatory)	
c) Parts catalogue/ microfiche/CD, supplied	Yes (mandatory)	
d) Operator's handbook supplied	Yes	
e) Service schedule supplied	Yes	
f) Training included.	Yes (mandatory)	
g) Crane test certificate provided	Yes (mandatory)	
h) Additional safety features – provide detail	Yes	
9. OTHER REQUIREMENTS.		
a) Manufacturer's authorization supplied when tendering.	Yes (mandatory)	
b) Evidence (in form of purchase documents) of minimum 10 units sold and serviced in Kenya.	Yes (Mandatory)	
c) Franchise Holders and dealers who own fully fledged workshop(s) equipment with adequate facilities.	Yes (Mandatory)	
d) Body construction and all fitments to conform to Kenya Traffic Act and to have a certificate from vehicle inspection centre.	Yes (mandatory)	
e) Crane to be inspected by the Senior Transport Engineer prior to delivery.	Yes (mandatory)	
f) Crane to be fitted onto the supplied cab chassis truck.	Yes (mandatory)	
g) Indicate name and physical addresses of all Dealers/Agents where Genuine Spares and back-up service can be obtained in at least one major Kenya Power depots (Nairobi, Mombasa, Kisumu, Nyeri, Nakuru and Eldoret).	Attach list – Yes (mandatory)	

MOTOR CYCLE, TRAIL, 120-130cc.**Quantity: 112****Specification No. KPLC-TPT-01-16-17.****Description: Motor cycle, trail, 120-130cc.****Tenderers' name:.....**

	KPLC requirements	Tenderer's Offer
1. GENERAL.		
a) Make:	-	
b) Model:	-	
c) Country of origin:	-	
d) Manufacturer's literature/brochures and specification supplied	Yes (mandatory)	
e) A standard production, motor cycle of latest design in class, in current production and marketed in Kenya.	Yes (mandatory)	
f) Capable of operating in tropical road conditions	Yes	
g) Supplied new	Yes (mandatory)	
2. DIMENSIONS AND WEIGHTS.		
a) Overall length approx.	2100 mm	
b) Overall width approx.	900 mm	
c) Overall height approx.	1100 mm	
d) Seat (saddle) height, approx.	850mm	
e) Wheelbase approx.	1300 mm	
f) Ground Clearance, approx.	260 mm (mandatory)	
g) Dry weight, approx.	100Kg	
3. ENGINE.		
a) Make	-	

b) Model	-	
c) Country of origin	-	
d) 2 stroke/4 stroke, air cooled, petrol engine	Specify	
e) Single cylinder	Yes	
f) Piston displacement, within range.	120-130cc (mandatory)	
g) Ignition system	Specify	
h) Starter system	Specify	
i) Maximum power output/rpm, min	12HP/9,000rpm Yes (mandatory)	
j) Maximum torque /rpm, min	9Nm/8000rpm Yes (mandatory)	
k) Average fuel consumption (on full load)	Specify Kms/lit	
l) Fuel Tank capacity, min.	9Lt.	
4. TRANSMISSION, BRAKES, TIRES AND SUSPENSION.		
a) Transmission, speed, minimum.	5 No.	
b) Final Transmission.	Chain drive	
c) Front and rear brakes	Drum	
d) Front size.	2.75-21-4PR	
e) Rear tyre size	4.10-18-4PR	
f) Suspension system, Front telescopic forks and rear mono-cross.	Yes (mandatory)	
5. ELECTRICAL SYSTEM/INSTRUMENTS		
a) Full lighting to conform to Kenya Traffic Act.	Yes	
b) Standard, major function gauges (speedometer, Tachometer, Odometer, trip counter, etc.)/and warning lights (oil warning light etc.) fitted.	Yes	
c) Fitted with suitable anti-theft alarm system.	Yes (mandatory)	

6. WARRANTY & FREE SERVICE.		
a) Each Motor cycle supplied should carry a statement of warranty	Yes	
b) Motor cycle warranty min., 6 Months or 6,000Km whichever comes first	Specify Months	
	Specify Kms	
c) Free Service on Labour & Parts	Parts (Kms)	
	Labour (Kms)	
7. MANUALS		
a) All literature in English language	Yes (mandatory)	
b) Repair manuals/microfiche/CD, supplied	Yes (mandatory)	
c) Parts catalogue/microfiche/CD, supplied	Yes (mandatory)	
d) Drivers handbook supplied	Yes	
e) Service schedule supplied	Yes	
8. OTHER REQUIREMENTS		
a) Motor cycle supplied with suitable crash helmet c/w eye protector and hand gloves.	Yes (mandatory)	
b) Motor cycle supplied complete with suitable standard fibreglass cargo box.	Yes (mandatory)	
c) Motor cycle to be painted in KPLC colour as per the user specification.	Yes (mandatory)	
d) Motor cycle to be registered by Registrar of Motor Vehicles.	Yes (mandatory)	
e) Motor cycle to be inspected by the Senior Transport Engineer prior to delivery.	Yes (mandatory)	
f) Firm's status: Franchise/Dealer/Agent	Specify	
g) g) Body construction and all fitments to conform to	Yes (mandatory)	

Kenya Traffic Act		
h) Indicate name and physical addresses of all Dealers/Agents where Genuine Spares and back-up service can be obtained In At least four major KPLC depots (Nairobi, Mombasa, Kisumu, Nyeri, Nakuru and Eldoret).	Attach list Yes (mandatory)	

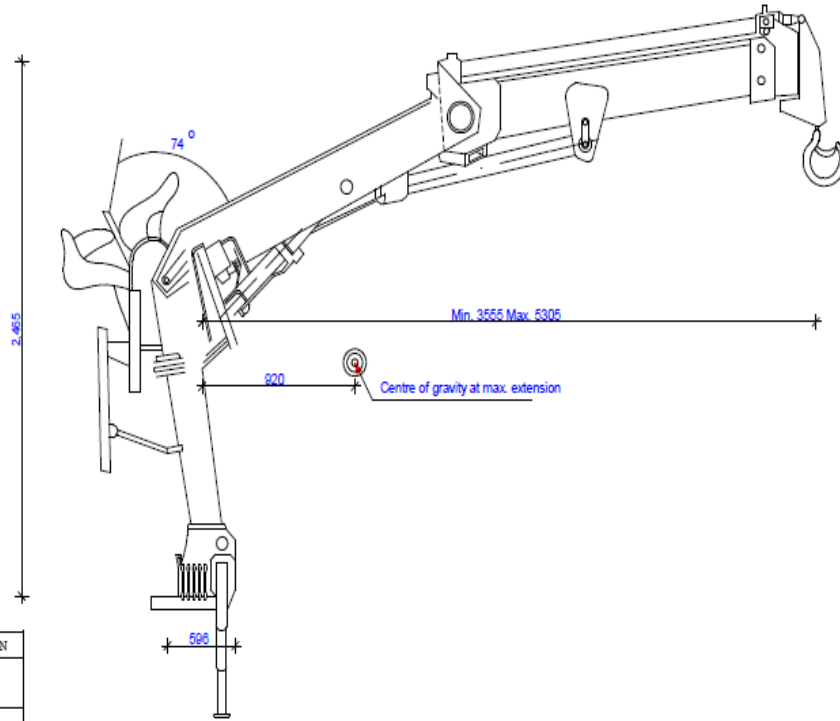

	DATE	SIGN
APPROVED		
CHECKED ENGINEER I/C		
CHECKED HEAD D/MAN		
CHECKED SUPERVISOR		
DRAWN	20/01/2003	J.M Kabare
SURVEYED		
TRACED		

REF	REVISION	DATE	SIGN	CHECKED	DATE

DESIGN OF K.P.L.C.
HIAB TRUCK MOUNTED CRANE
 NOT TO SCALE

Sheet J2

K. P. & L. Co. LTD

SK. No. 09366

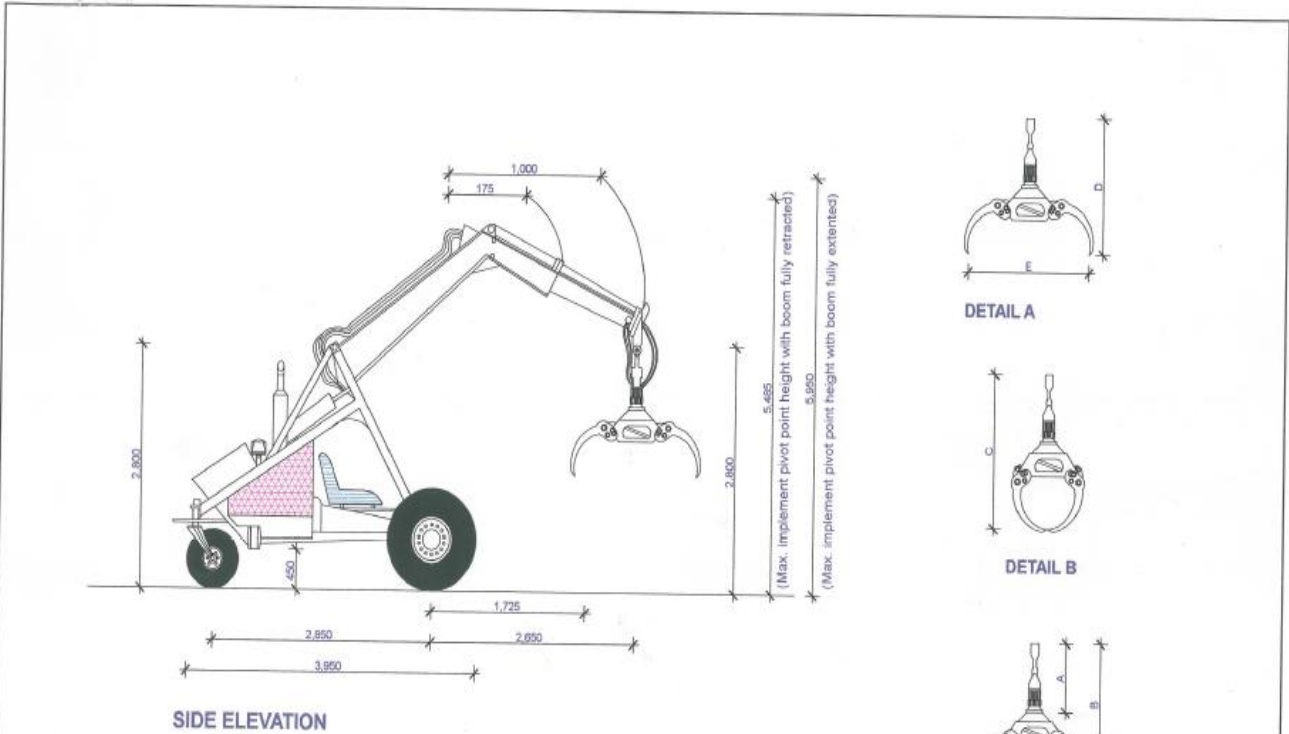

SIDE ELEVATION



DETAIL A

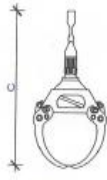

DETAIL B

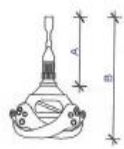

DETAIL C

APPROVED	DATE	SIGN
CHECKED		
ENGINEER DC		
CHECKED		
HEAD DPMAN		
CHECKED		
SURVEYOR		

REF	REVISION	DATE	SIGN	CHECKED	DATE

.DESIGN OF K.P.L.C
WHEEL LOADER - LOGGER

NOT TO SCALE

Sheet N

K. P. & L. Co. LTD

SK. No. 09366

NOTES:
 SIDE GATES TO BE FABRICATED AND DURABLE HINGES MADE TO SUIT THE DROP GATES.
 CARGO BAY FLOOR SHEET TO BE AT LEAST 3MM THK
 SIDE PANELS INCLUDING DROPSIDE GATES TO BE OF AT LEAST 2.5THK WITH APPROPRIATE REINFORCEMENTS
 WHEREVER ARC WELDING IS USED ALL THE WELD JOINTS MUST BE THOROUGHLY CLEANED OFF SLUGS AND WELD JOINTS CHECKED TO CONFORM TO BE STANDARDS

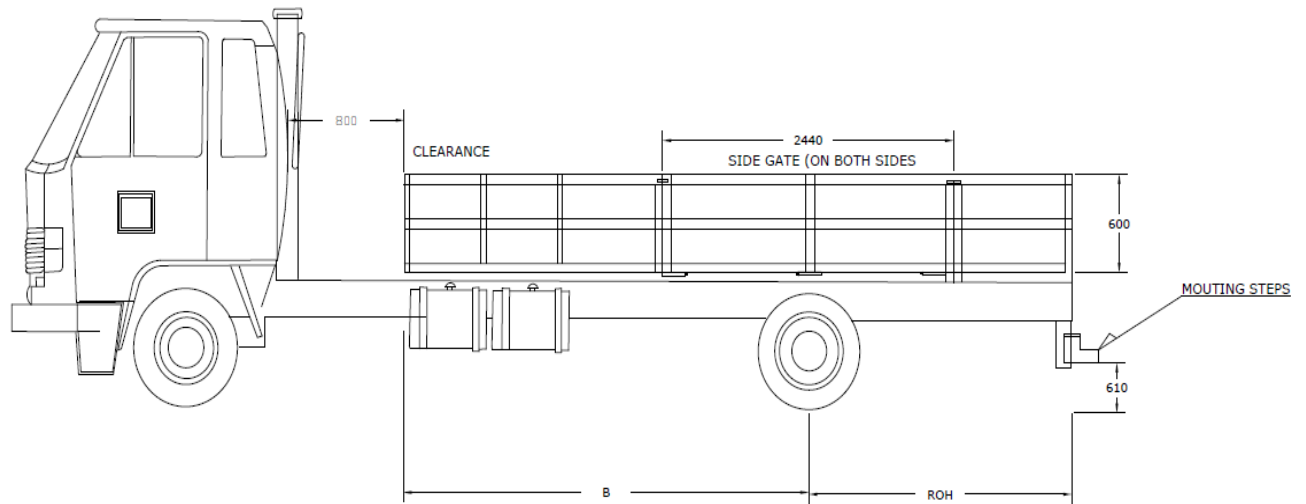

	DATE	ISSUE	BY
APPROVED			
DESIGNED			
CHECKED			
DATE	ISSUE	CHECKED	DATE

DESIGN OF K.P.L.C HIAB MOUNTED TRUCK

(DRAWN NOT TO SCALE)

SHEET J/1

K.P.&L.Co. Ltd.

SK. No. 09366